



# **SKUKUZA AIRPORT PPP AGREEMENT**

**PUBLIC PRIVATE PARTNERSHIP AGREEMENT**

**FOR THE**

**MANAGEMENT AND OPERATION OF THE SKUKUZA AIRPORT**

**IN THE**

**KRUGER NATIONAL PARK**

**October 2008**

**TABLE OF CONTENTS**

|             |  |           |
|-------------|--|-----------|
| <b>1.</b>   | <b>DEFINITION AND INTERPRETATION.....</b>                              | <b>7</b>  |
| <b>2.</b>   | <b>INTRODUCTION .....</b>  | <b>20</b> |
| <b>3.</b>   | <b>PROJECT TERM.....</b>   | <b>21</b> |
| <b>4.</b>   | <b>STATUS OF THIS PPP AGREEMENT.....</b>                               | <b>21</b> |
| <b>5.</b>   | <b>PPP RIGHTS .....</b>  | <b>21</b> |
| <b>5.1</b>  | <b>EXCLUSIVE GRANT OF PPP RIGHTS.....</b>                              | <b>21</b> |
| <b>5.2</b>  | <b>SKUKUZA AIRPORT RIGHTS .....</b>                                    | <b>22</b> |
| <b>5.3</b>  | <b>SERVICE DELIVERY .....</b>  | <b>23</b> |
| <b>6.</b>   | <b>OPERATION, MANAGEMENT AND MAINTENANCE.....</b>                      | <b>25</b> |
| <b>6.1</b>  | <b>OPERATION, MANAGEMENT AND MAINTENANCE BY THE PRIVATE PARTY.....</b> | <b>25</b> |
| <b>6.2</b>  | <b>UNAUTHORISED PAYMENTS .....</b>                                     | <b>26</b> |
| <b>6.3</b>  | <b>THIRD PARTY CONTRACTS.....</b>                                      | <b>27</b> |
| <b>7.</b>   | <b>LABOUR LAWS .....</b>   | <b>27</b> |
| <b>8.</b>   | <b>PRIVATE PARTY COVENANTS .....</b>                                   | <b>28</b> |
| <b>9.</b>   | <b>COMMERCIAL BRANDING .....</b>                                       | <b>30</b> |
| <b>10.</b>  | <b>PROJECT SITE .....</b>  | <b>30</b> |
| <b>10.1</b> | <b>SKUKUZA AIRPORT .....</b>   | <b>30</b> |
| <b>10.2</b> | <b>ACCESS FOLLOWING COMMENCEMENT .....</b>                             | <b>30</b> |
| <b>10.3</b> | <b>SUITABILITY AND CONDITION OF THE SKUKUZA AIRPORT .....</b>          | <b>31</b> |
| <b>11.</b>  | <b>HANDOVER.....</b>   | <b>31</b> |
| <b>12.</b>  | <b>THE ENVIRONMENT .....</b>   | <b>32</b> |
| <b>13.</b>  | <b>SANPARKS’ REMEDIAL RIGHTS.....</b>                                  | <b>33</b> |
| <b>14.</b>  | <b>SANPARKS’ UNDERTAKINGS AND RESPONSIBILITIES .....</b>               | <b>33</b> |
| <b>15.</b>  | <b>BLACK ECONOMIC EMPOWERMENT.....</b>                                 | <b>35</b> |
| <b>16.</b>  | <b>FINANCIAL PROVISIONS AND PAYMENT .....</b>                          | <b>35</b> |
| <b>16.1</b> | <b>GROSS REVENUE .....</b>   | <b>35</b> |

|       |   |    |
|-------|---|----|
| 16.2  | PPP FEES.....   | 36 |
| 16.3  | NOTWITHSTANDING THAT ALL CONSIDERATION PAYABLE HEREUNDER SHALL BE DEEMED TO BE EXCLUSIVE OF VALUE ADDED TAX PAYABLE IN TERMS OF THE THE VAT ACT”, AND ANY OTHER RATES, TAXES, DUTIES, CHARGES OR IMPOSTS WHICH MAY BE OR BECOME PAYABLE THEREON, THE PRIVATE PARTY SHALL BE OBLIGED, AT ALL TIMES, TO PAY VALUE ADDED TAX, AS REQUIRED BY THE VAT ACT. .... | 37 |
| 17.   | PERFORMANCE BOND.....   | 37 |
| 18.   | SALE OF BUSINESS.....   | 39 |
| 18.1  | INTRODUCTION .....  | 39 |
| 18.2  | SALE ASSETS .....   | 40 |
| 18.3  | PURCHASE PRICE .....  | 40 |
| 18.4  | PAYMENT .....   | 41 |
| 18.5  | POSSESSION .....  | 41 |
| 18.6  | DEBTORS.....  | 41 |
| 18.7  | AUTOMATIC BUY-BACK.....   | 41 |
| 18.8  | INSOLVENCY ACT PUBLICATION .....  | 42 |
| 18.9  | VOETSTOOTS .....  | 43 |
| 18.10 | EMPLOYEES.....  | 43 |
| 19.   | INSURANCE.....  | 43 |
| 19.6  | THE PRIVATE PARTY SHALL BE OBLIGED TO UTILISE THE PROCEEDS OF ANY POLICY IN RESPECT OF THE DAMAGE TO OR DESTRUCTION OF ANY PROJECT ASSET TO REPAIR OR REPLACE SUCH PROJECT ASSET. ....  | 44 |
| 20.   | INDEMNITIES AND LIABILITY .....   | 44 |
| 20.1  | PRIVATE PARTY INDEMNITY.....  | 45 |
| 20.2  | LEGAL ACTION.....   | 45 |
| 21.   | GENERAL REPORTING AND FINANCIAL REPORTING REQUIREMENTS.....   | 46 |
| 21.1  | GENERAL REPORTING.....  | 46 |
| 21.2  | ANNUAL FINANCIAL REPORTING.....   | 47 |
| 21.3  | REQUESTS FOR INFORMATION .....  | 47 |
| 22.   | DEFAULT INTEREST .....  | 47 |
| 23.   | FORCE MAJEURE.....  | 47 |
| 23.1  | DEFINITION AND PROCEDURE.....   | 48 |
| 23.2  | TERMINATION FOR FORCE MAJEURE .....   | 49 |

|            |  |           |
|------------|--|-----------|
| <b>24.</b> | <b>PRIVATE PARTY DEFAULT .....</b>                         | <b>50</b> |
| 24.1       | <b>DEFINITION.....</b>                                     | <b>50</b> |
| 24.2       | <b>SANPARKS’ OPTIONS.....</b>                              | <b>51</b> |
| 24.3       | <b>SANPARKS’ COSTS.....</b>                                | <b>52</b> |
| 24.4       | <b>TERMINATION AMOUNT ON PRIVATE PARTY DEFAULT .....</b>   | <b>52</b> |
| <b>25.</b> | <b>SANPARKS DEFAULT.....</b>                               | <b>53</b> |
| 25.1       | <b>DEFINITION.....</b>                                     | <b>53</b> |
| 25.2       | <b>TERMINATION FOR SANPARKS DEFAULT .....</b>              | <b>53</b> |
| 25.3       | <b>TERMINATION AMOUNT FOR SANPARKS DEFAULT .....</b>       | <b>53</b> |
| <b>26.</b> | <b>TERMINATION BY NOTICE .....</b>                         | <b>53</b> |
| <b>27.</b> | <b>CORRUPT GIFTS AND FRAUD.....</b>                        | <b>54</b> |
| 27.1       | <b>DEFINITION AND WARRANTY .....</b>                       | <b>54</b> |
| 27.2       | <b>TERMINATION AMOUNT FOR CORRUPT GIFTS AND FRAUD.....</b> | <b>55</b> |
| <b>28.</b> | <b>CONFIDENTIALITY.....</b>                                | <b>55</b> |
| <b>29.</b> | <b>DISPUTE RESOLUTION.....</b>                             | <b>56</b> |
| 29.1       | <b>REFERABLE DISPUTES .....</b>                            | <b>56</b> |
| 29.2       | <b>INTERNAL REFERRAL .....</b>                             | <b>56</b> |
| 29.3       | <b>PERFORMANCE TO CONTINUE .....</b>                       | <b>57</b> |
| 29.4       | <b>LITIGATION.....</b>                                     | <b>57</b> |
| <b>30.</b> | <b>EFFECT OF EXPIRY OR TERMINATION.....</b>                | <b>57</b> |
| <b>31.</b> | <b>EXIT PROVISIONS.....</b>                                | <b>59</b> |
| <b>32.</b> | <b>CHANGES IN CONTROL .....</b>                            | <b>60</b> |
| <b>33.</b> | <b>CESSION, TRANSFER AND SUBSTITUTED ENTITY .....</b>      | <b>60</b> |
| <b>34.</b> | <b>INTELLECTUAL PROPERTY.....</b>                          | <b>63</b> |
| <b>35.</b> | <b>AMENDMENTS .....</b>                                    | <b>65</b> |
| <b>36.</b> | <b>ENTIRE AGREEMENT.....</b>                               | <b>65</b> |
| <b>37.</b> | <b>VARIATION, CANCELLATION AND WAIVER.....</b>             | <b>65</b> |
| <b>38.</b> | <b>LIMITATIONS ON PRIVATE PARTY ENCUMBRANCES.....</b>      | <b>66</b> |

|              |   |           |
|--------------|---|-----------|
| <b>39.</b>   | <b>GOVERNING LAW AND JURISDICTION</b> .....                             | <b>66</b> |
| <b>40.</b>   | <b>STIPULATIONS FOR THE BENEFIT OF THE LENDERS</b> .....                | <b>66</b> |
| <b>41.</b>   | <b>NOTICES</b> .....  | <b>67</b> |
| <b>42.</b>   | <b>SCHEDULE 1 - DESCRIPTION OF THE SKUKUZA AIRPORT FACILITIES</b> ..... | <b>69</b> |
| <b>42.1</b>  | <b>SKUKUZA AIRPORT</b> .....  | <b>69</b> |
| <b>43.</b>   | <b>SCHEDULE 2 – SITE DRAWINGS OF SKUKUZA AIRPORT</b> .....              | <b>71</b> |
| <b>43.1</b>  | <b>AIRPORT BUILDING:</b> .....  | <b>71</b> |
| <b>43.2</b>  | <b>OTHER AIRPORT BUILDINGS</b> .....                                    | <b>71</b> |
| <b>43.3</b>  | <b>RUNWAY CROSS SECTION</b> .....                                       | <b>72</b> |
| <b>44.</b>   | <b>SCHEDULE 3 – PRIVATE PARTY OPERATIONAL REQUIREMENTS</b> .....        | <b>73</b> |
| <b>44.1</b>  | <b>FLIGHTS AND FLIGHT TRACKS</b> .....                                  | <b>73</b> |
| <b>44.2</b>  | <b>CONDUCT OF BUSINESS</b> .....  | <b>73</b> |
| <b>44.3</b>  | <b>BRANDING</b> .....   | <b>74</b> |
| <b>44.4</b>  | <b>SERVICE PROVISION / OPERATING HOURS</b> .....                        | <b>74</b> |
| <b>44.5</b>  | <b>FACILITIES AND SERVICES</b> .....                                    | <b>74</b> |
| <b>44.6</b>  | <b>UNIFORMS</b> .....   | <b>75</b> |
| <b>44.7</b>  | <b>BENCHMARK PRICING AND CONTROL</b> .....                              | <b>75</b> |
| <b>44.8</b>  | <b>SKUKUZA AIRPORT STAFF AND STAFF TRANSPORT</b> .....                  | <b>75</b> |
| <b>44.9</b>  | <b>STAFF HOUSING</b> .....  | <b>75</b> |
| <b>44.10</b> | <b>UTILITY CHARGES</b> .....  | <b>76</b> |
| <b>44.11</b> | <b>MEETINGS</b> .....   | <b>77</b> |
| <b>44.12</b> | <b>PROCEDURE MANUALS</b> .....  | <b>77</b> |
| <b>44.13</b> | <b>QUALITY AUDIT</b> .....  | <b>77</b> |
| <b>44.14</b> | <b>INSTITUTIONAL POLICIES AND OBJECTIVES</b> .....                      | <b>77</b> |
| <b>44.15</b> | <b>GAMES</b> .....  | <b>77</b> |
| <b>44.16</b> | <b>PUBLICATIONS</b> .....   | <b>78</b> |
| <b>45.</b>   | <b>SCHEDULE 4 – PRIVATE PARTY BID SUBMISSION</b> .....                  | <b>79</b> |
| <b>46.</b>   | <b>SCHEDULE 5 – BEE OBLIGATIONS</b> .....                               | <b>80</b> |
| <b>47.</b>   | <b>SCHEDULE 6 – PPP FEE</b> .....                                       | <b>90</b> |
| <b>47.1</b>  | <b>VARIABLE PPP FEE</b> .....   | <b>90</b> |
| <b>47.2</b>  | <b>MINIMUM PPP FEE</b> .....  | <b>90</b> |

|      |  |            |
|------|--|------------|
| 48.  | <b>SCHEDULE 7 – SALE ASSETS</b> .....  | <b>91</b>  |
| 49.  | <b>SCHEDULE 8 – EMPLOYEES</b> .....  | <b>92</b>  |
| 50.  | <b>SCHEDULE 9 – ENVIRONMENTAL SPECIFICATIONS FOR THE OPERATION OF THE SKUKUZA AIRPORT WITHIN THE PROTECTED AREAS</b> ..... | <b>93</b>  |
| 50.1 | <b>INTRODUCTION</b> .....  | <b>93</b>  |
| 50.2 | <b>LEGISLATIVE BASIS FOR THESE GUIDELINES</b> .....  | <b>93</b>  |
| 50.3 | <b>GUIDELINES BASED ON SANPARKS INTERNAL REQUIREMENTS</b> .....  | <b>94</b>  |
| 50.4 | <b>CODE OF CONDUCT</b> .....   | <b>96</b>  |
| 50.5 | <b>ENVIRONMENTAL SPECIFICATIONS</b> .....  | <b>96</b>  |
| 51.  | <b>SCHEDULE 10 – PRIVATE PARTY CONSTITUTIONAL DOCUMENTS</b> .....  | <b>103</b> |
| 52.  | <b>SCHEDULE 11 – INSURANCE</b> .....   | <b>104</b> |
| 53.  | <b>SCHEDULE 12 – PERFORMANCE BOND</b> .....  | <b>105</b> |
| 54.  | <b>SCHEDULE 13 – CAPITAL EXPENDITURE PLAN</b> .....  | <b>110</b> |
| 54.1 | <b>INTRODUCTION</b> .....  | <b>110</b> |
| 54.2 | <b>DETAILS ON CAPITAL EXPENDITURE</b> .....  | <b>110</b> |
| 55.  | <b>SCHEDULE 14 – EMPLOYEE HOUSING AND RENTALS</b> .....  | <b>111</b> |
| 56.  | <b>SCHEDULE 15 – PRIVATE PARTY LOAN AGREEMENTS</b> .....   | <b>112</b> |
| 57.  | <b>SCHEDULE 16 - TRIBAL AUTHORITIES NEIGHBOURING THE KNP</b> .....   | <b>113</b> |
| 57.1 | <b>NTIRHISWANO FORUM TRIBAL AUTHORITIES</b> .....  | <b>113</b> |
| 57.2 | <b>LUBAMBISWANO FORUM TRIBAL AUTHORITIES</b> .....   | <b>113</b> |
| 57.3 | <b>MAHLAMBA NDLOPFU FORUM TRIBAL AUTHORITIES</b> .....   | <b>113</b> |
| 57.4 | <b>NKOMAZI – SUKUMANI FORUM TRIBAL AUTHORITIES</b> .....   | <b>113</b> |
| 57.5 | <b>HLANGANANI FORUM TRIBAL AUTHORITIES</b> .....   | <b>114</b> |
| 57.6 | <b>MAKUYA FORUM TRIBAL AUTHORITIES</b> .....   | <b>114</b> |
| 57.7 | <b>PHALABORWA FORUM TRIBAL AUTHORITIES</b> .....   | <b>114</b> |
| 58.  | <b>SCHEDULE 17 – FLIGHT PATHS</b> .....  | <b>116</b> |
| 59.  | <b>SCHEDULE 18 – PCN CALCULATION REPORT</b> .....  | <b>117</b> |
| 60.  | <b>SCHEDULE 19 – DRAFT EMP AND SPECIALIST STUDY FOR THE COMMERCIALISATION OF THE SKUKUZA AIRPORT (SIVEST)</b> .....        | <b>118</b> |

## 1. DEFINITION AND INTERPRETATION

1.1 In this PPP Agreement and its Schedules, the following terms shall, unless inconsistent with the context in which they appear have the following meanings and expressions derived from those terms shall bear corresponding meanings:

- 1.1.1 **“ACN”** - Aircraft Classification Number;
- 1.1.2 **“Act”** - the National Environmental Management: Protected Areas Act, 2003 (Act No. 57 of 2003) (as amended);
- 1.1.3 **“AOM”** - Airport Operations Manual, prepared in accordance with the provisions of CAR and CATS-AH;
- 1.1.4 **“Aviation Act”** - The Aviation Act, No. 74 of 1962;
- 1.1.5 **“BEE Obligations”** - the Black Economic Empowerment requirements detailed in SCHEDULE 5 – BEE OBLIGATIONS;
- 1.1.6 **“Good Industry Practice”** - the exercise of that degree of skill, diligence, prudence and foresight which would reasonably and ordinarily be expected from time to time from a skilled and experienced contractor or professional, engaged in the same type of undertaking and under the same or similar circumstances and conditions as those envisaged by this PPP Agreement; seeking in good faith to comply with his contractual obligations and all applicable Regulatory Provisions, upholding the integrity of SANParks, the intention being that an acceptable balance shall be maintained between tourism and conservation;
- 1.1.7 **“Bid Submission”** - the bid for the right to carry out the Project submitted by the Private Party and accepted by SANParks;

- 1.1.8 **“Black Economic Empowerment” or “BEE”** - an integrated and coherent socio-economic process that directly contributes to the economic transformation of South Africa and brings about significant increases in the number of Black People who manage, own and control the country's economy, as well as significant decreases in income inequalities, as defined in the Broad Based Black Economic Empowerment Act;
- 1.1.9 **“Business Day”** - any day other than a Saturday, Sunday and/or official Public holiday in the Republic of South Africa;
- 1.1.10 **“CAA”** - the South African Civil Aviation Authority;
- 1.1.11 **“CAR”** - The Civil Aviation Regulations 1997;
- 1.1.12 **“CATEGORY/category”** - The categorisation of airports as referred to in CAR 139.02.7(2), CATS-AH 139.02.07 and paragraph 9.2 of Annex 14, Volume I of ICAO;
- 1.1.13 **“CATS-AH”** - The Civil Aviation Technical Standards in respect of aerodromes;
- 1.1.14 **“Change in Control”** - Any change whatsoever in Control, whether effected directly or indirectly;
- 1.1.15 **“Consents”** - all consents, permits, clearances authorisations, approvals, rulings, exemptions, registrations, filings, decisions, licences, certificates required to be issued by or made with any Responsible Authority in connection with the performance of any of the Project Deliverables;



- 1.1.16 **“Constitutional Documents”**
- The Private Party's memorandum and articles of association, certificate of incorporation and certificate to commence business, as well as the Shareholders PPP Agreement, equity subscription agreements and equity guarantees entered into and provided in respect of the Private Party and any documents or agreements in respect of any debentures issued by the Private Party, all of which are attached to this PPP Agreement as SCHEDULE 10 – PRIVATE PARTY CONSTITUTIONAL DOCUMENTS and the terms of which are to be to the satisfaction of SANParks;
- 1.1.17 **“Control”**
- in relation to any entity, the ability directly or indirectly to direct or cause the direction of the votes attaching to the majority of its issued shares or interests carrying voting rights, or to appoint or remove or cause the appointment or removal of any directors (or equivalent officials) or those of its directors (or equivalent officials) holding the majority of the voting rights on its board of directors (or equivalent body);
- 1.1.18 **“CPIX”**
- the consumer price index excluding interest on mortgage bonds, for metropolitan and other urban areas (Base 2000=100) published from time to time by Statistics SA in Statistical Release P0141.1;
- 1.1.19 **“Effective Date”**
- the date of signature of this PPP Agreement by the first signing Party;
- 1.1.20 **“EIA” or “Environmental Impact Assessment”**
- the process of assessing the Environmental effects of a development or an activity and its subsequent operation, carried out in accordance with applicable Regulatory Provisions and guidelines;
- 1.1.21 **“Employees”**
- all the employees of the Business, the names of whom are set out in SCHEDULE 8 – EMPLOYEES;

- 
- 1.1.22 **“Environment”** - the aggregate of surrounding objects, conditions and influences that influence the life and habitats of humans or any other organism or collection of organisms, and including all or any of the following media: air (including the air within any building or the air within any other man-made or natural structure above or below ground), water (including inland waters, groundwater and water in drains and sewers) and land;
- 1.1.23 **“Environmental Laws”** - any Laws in respect of the Environment, including (without limitation) at the Signature Date, the following statutes: the National Water Act 36 of 1998; the Water Services Act, 108 of 1997; ; the National Environmental Management Act, 107 of 1998; the National Environmental Management: Protected Areas Act, 57 of 2003; the National Environmental Management: Air Quality Act; the Hazardous Substances Act, 15 of 1973; and the National Heritage Resources Act, 25 of 1999;
- 1.1.24 **“Environmental Specifications”** - the requirements, conditions, obligations and specifications detailed in SCHEDULE 9 – ENVIRONMENTAL SPECIFICATIONS FOR THE OPERATION OF THE SKUKUZA AIRPORT WITHIN THE PROTECTED AREAS;
- 1.1.25 **“Expiry Date”** - shall be 24h00 on the tenth (10<sup>th</sup>) anniversary of the Operation Commencement Date;
- 1.1.26 **“Force Majeure”** - has the meaning ascribed to it in Clause 23;
- 1.1.27 **“GAAP”** - generally accepted accounting practice in the Republic of South Africa as approved from time to time by the South African Accounting Standards Board;
- 1.1.28 **“Gross Revenue”** - gross revenue has the meaning as defined in Clause 16;
- 1.1.29 **“Handover Period”** - the period between the Effective Date and the Operation Commencement Date;
- 1.1.30 **“ICAO”** - International Civil Aviation Organisation;

- 
- 1.1.31 **“Intellectual Property Rights”** - all registered or unregistered trade marks, service marks, patents, design rights (whether the aforementioned rights are registered, unregistered or formed pending applications), utility models, applications for any of the a foregoing, copyrights (including copyright in any software programmes, data and documents), database rights, the sui generis rights of extraction relating to databases and any similar or analogous rights to any of the above, whether arising or granted under the Laws or any other jurisdiction;
- 1.1.32 **“KNP”** - Kruger National Park;
- 1.1.33 **“Laws”** - the common law, Legislation, and all judicial decisions and any notifications or other similar directives made pursuant thereto that have the force of law, issued by any executive, legislative, judicial or administrative entity in South Africa or by SANParks or the municipality in which the Project is located;
- 1.1.34 **“Legislation”** - all applicable statutes, statutory instruments, by-laws, Regulations, orders, rules, executive orders and other secondary, provincial or local Legislation, treaties, directives and codes of practice having force of law in South Africa;
- 1.1.35 **“Lenders”** - means any person providing financing to the Private Party for the project, other than shareholders of the Private Party;
- 1.1.36 **“Local”** - the geographic area specified by SANParks in the Request for Proposals issued by SANParks in respect of the Project, being the tribal authorities attached as SCHEDULE 16 - TRIBAL AUTHORITIES NEIGHBOURING THE KNP;
- 1.1.37 **“Losses”** - losses, damages, liabilities, claims, actions, proceedings, demands, costs, charges or expenses of any nature;

- 
- 1.1.38 **“Minimum PPP Fee”** - that portion of the PPP Fee that is payable by the Private Party at all times after the Operation Commencement Date, regardless of the amount of the Gross Revenue, which amount is detailed in Clause 16;
- 1.1.39 **“New Project Assets”** - The movable assets, other than the Sale Assets and any replacement assets as per Clause 18.7.3, acquired by the Private Party to operate the Skukuza Airport as the relevant category airport;
- 1.1.40 **“OEMG”** - Operational Environmental Management Guideline;
- 1.1.41 **“Operation Commencement Date”** - the date of Operation Commencement, specifically 15 March 2009;
- 1.1.42 **“Operation Period”** - the period from the Operation Commencement Date to the Expiry Date, unless this PPP Agreement is terminated earlier in accordance with its terms;
- 1.1.43 **“Park”** - Kruger National Park;
- 1.1.44 **“Park Management Plan”** - SANParks’ management plan or its impact management plan in respect of the Protected Area;
- 1.1.45 **“Park Manager”** - the Managing Executive for the Kruger National Park;
- 1.1.46 **“Parties”** - collectively, SANParks and the Private Party;
- 1.1.47 **“Party”** - SANParks or the Private Party, as the case may be;
- 1.1.48 **“PCN”** - Pavement Classification Number;
- 1.1.49 **“Performance Bond”** - the guarantee to be issued by a financial institution in favour of SANParks on behalf of the Private Party, in respect of the Private Party's obligations to comply with the Environmental Specifications and the Project Specifications, to undertake the Project, which guarantee shall be substantially in the form of the document attached to this PPP Agreement as SCHEDULE 12 – PERFORMANCE BOND;
- 1.1.50 **“Person”** - any individual, partnership, corporation, company, business organisation trust, governmental agency, para-statal, Relevant Authority or other entity;

- 1.1.51 **“PPP Agreement”** - this agreement between SANParks and the Private Party including the Schedules hereto as amended, extended, replaced and varied from time to time;
- 1.1.52 **“PPP Fee”** - the fee payable by the Private Party to SANParks in respect of the Project, as detailed in Clause 16;
- 1.1.53 **“PPP Rights”** - the right to operate and manage the Skukuza Airport and in exchange receive all landing charges, parking charges and passenger service charges as a result of aircraft flying into the Skukuza Airport;
- 1.1.54 **“PPP”** - public private partnership, as defined in the Treasury Regulations promulgated under the Public Finance Management Act, 1999;
- 1.1.55 **“Private Party Default”** - has the meaning ascribed to it in Clause 24;
- 1.1.56 **“Private Party Parties”** - the officers, directors, staff, employees, contractors, sub-contractors, agents, guests, visitors, invitees and patrons of the Private Party or, where the context requires, any one or more of them;
- 1.1.57 **“Private Party”** - the counterparty to SANParks hereunder;
- 1.1.58 **“Project Assets”** - all assets required to operate and/or manage the Project, including the airport buildings, but excluding all cash and cash equivalents;

- 1.1.59 **“Project Deliverables”** - means:
- the meeting of the BEE Obligations,
  - obtaining and successfully renewing, as may be required from time to time, a CAA airport licence that will allow the Skukuza Airport to be operated as the relevant category (4 or 5, in accordance with the Bid Submission) airport;
  - the operation and management of scheduled flights, chartered flights and management flights of SANParks aircraft at the Skukuza Airport. The operation and management should be done in line with the OEMG and the AOM. SANParks aircraft should be managed according to the SMAOM that was compiled specifically for SANParks’ management aircraft;
  - sourcing and contracting with an appropriate carrier that will be responsible for scheduled flights;
  - undertaking of the Project including the execution of the PPP Rights; and
  - the exercise and performance of all other rights and obligations of the Private Party under this PPP Agreement and the Schedules from time to time;
- 1.1.60 **“Project Insurance”** - those insurances that the Private Party is required by Law and this PPP Agreement to purchase and maintain in terms of Clause 19 a copy of which is attached as SCHEDULE 11 – INSURANCE;
- 1.1.61 **“Project Term”** - the period from the Operation Commencement Date to the Expiry Date or the Termination Date, whichever occurs first
- 1.1.62 **“Project Year”** - each period of twelve (12) consecutive months, commencing on the Operation Commencement Date and thereafter commencing on every anniversary of the Operation Commencement Date;

- 1.1.63 **“Project”** - the project to refurbish the airport buildings according to the category proposed in the bid submission, to operate and manage the Skukuza Airport and to execute the PPP Rights as detailed in this PPP Agreement;
- 1.1.64 **“Protected Area”** - Kruger National Park;
- 1.1.65 **“Purchase Price”** - the purchase price to be paid by the Private Party to SANParks in respect of the Sale Assets in terms of Clause 18.3;
- 1.1.66 **“Rand” or “R”** - the lawful currency of South Africa;
- 1.1.67 **“Regulations”** - Regulations issued in terms of the Act;
- 1.1.68 **“Regulatory Provisions”** - (a) the Environmental guidelines (“Environmental Specifications”) for operators operating within the Protected Area which is further described in SCHEDULE 9 – ENVIRONMENTAL SPECIFICATIONS FOR THE OPERATION OF THE SKUKUZA AIRPORT WITHIN THE PROTECTED AREAS, as same may be revised and updated by SANParks from time to time; and  
(b) collectively the prevailing laws, Regulations, ordinances, policy directives and standards of the State and any Relevant Authority which in any way affects or applies to the conducting of the Project and/or this PPP Agreement from time to time or, if the context is appropriate, any one of them and where appropriate includes the Park Management Plan, Rules and Regulations applicable to the Protected Area, Aviation Act, CAR, CATS-AH and standards of the ICAO enjoying the force of law in South Africa;

- 
- 1.1.69 **“Responsible Authority”** - National and/or Provincial legislature, any agency, local institution, department, inspectorate, minister, ministry, official or public or statutory person (whether autonomous or not) having jurisdiction over any or all of the Parties or the subject matter of this PPP Agreement. A Responsible Authority shall not include any Utility operator or provider;
- 1.1.70 **“Responsible Person”** - for the purposes of Clause 20, any contractor, sub-contractor at any level, agent, servant, officer or employee of the Private Party;
- 1.1.71 **“Airport Facilities”** - the land, buildings and other facilities together with all supporting infrastructure, plant and equipment, extant on the Operation Commencement Date, which are further described in SCHEDULE 1 - DESCRIPTION OF THE SKUKUZA AIRPORT FACILITIES and the attached site drawings in SCHEDULE 2 – SITE DRAWINGS OF SKUKUZA AIRPORT, and any new facilities constructed or developed by the Private Party during the Project Term, as required to enable the Private Party to exercise its rights and perform its obligations in terms of the Project Deliverables;
- 1.1.72 **“Sale Assets”** - those assets which are listed under SCHEDULE 7 – SALE ASSETS and which are sold by SANParks to the Private Party;
- 1.1.73 **“Sale of Business”** - the sale of business, which forms an integral part of this PPP Agreement, in terms of which inter alia the Sale Assets is acquired by the Private Party;
- 1.1.74 **“SANParks”** - South African National Parks, a statutory body established in terms of section 5 of the National Parks Act, No. 57 of 1976 and continuing to exist as a juristic person in terms of the provisions of section 54 of the National Environmental Management: Protected Areas Act, 2003 (Act No. 57 of 2003) and its lawfully designated representatives from time to time;



- 1.1.75 **“SMAOM”** - SANParks Management Aircraft Operational Manual;
- 1.1.76 **“Schedules”** - the schedules to this PPP Agreement, as amended, replaced and varied from time to time;
- 1.1.77 **“Signature Date”** - the date of signature of this PPP Agreement by SANParks;
- 1.1.78 **“Skills Development Spend”** - has the meaning as set out in SCHEDULE 5 – BEE OBLIGATIONS;
- 1.1.79 **“Skukuza Airport”** - the land and buildings utilised to operate the airport in the vicinity of Skukuza Camp, as reflected in SCHEDULE 2 - SITE DRAWINGS OF SKUKUZA AIRPORT;
- 1.1.80 **“South Africa”** - the Republic of South Africa;
- 1.1.81 **“State”** - the Government of the Republic of South Africa, acting directly or through its lawfully designated representatives;
- 1.1.82 **“Subcontractors”** - any subcontractor of the Private Party and a third party, who has contracted directly with the Private Party in respect of the Project;
- 1.1.83 **“Termination Amount”** - the amount payable on termination of this PPP Agreement in terms of Clause 24.4;
- 1.1.84 **“Termination Date”** - any date of early termination of this PPP Agreement, in accordance with its terms;
- 1.1.85 **“The Business”** - the business of the Skukuza Airport currently operated by SANParks (through SANParks Airport Services - SAS) but specifically excluding, for the avoidance of doubt, the Liabilities and all Debtors , in respect of which the cause of action shall have arisen prior to the Operation Commencement Date;

- 1.1.86 **“the Liabilities”** - all liabilities and obligations of the Business, incurred in the normal course, in respect of any period prior to the Operation Commencement Date or in respect of which the cause of action shall have arisen prior to the Operation Commencement Date, whether then due or not, including, but not by way of limitation, all actual and/or contingent liabilities, for payment of money, performance of services and obligations, supply of products and/or other performances;
- 1.1.87 **“the Stock”** - the stock-in-trade of the Business as at the Operation Commencement Date, including goods-in-transit (being stock purchased by SANParks prior to, but not yet delivered to SANParks on, the Operation Commencement Date), but excluding goods sold by SANParks and not yet delivered to the buyers of those goods at the Operation Commencement Date;
- 1.1.88 **“Utilities”** - all facilities, such as water, electricity, sewage, gas and telecommunications and, where appropriate, includes the relevant provider thereof;
- 1.1.89 **“Variable PPP Fee”** - that portion of the PPP Fee that is a percentage of the Gross Revenue of the Private Party, which percentage is detailed in Clause 16 and SCHEDULE 6 – PPP FEE;
- 1.1.90 **“VAT”** - Value Added Tax, as defined in the Value Added Tax Act, 1991 (Act No. 89 of 1991), (the “VAT Act”) or any similar tax which is imposed in place of or in addition to such tax;

1.2 This PPP Agreement shall be interpreted according to the following provisions, unless the context requires otherwise:

1.2.1 references to the provisions of any law shall include such provisions as amended, re-enacted or consolidated from time to time in so far as such amendment, re-enactment or consolidation applies or is capable of applying to any

- transaction entered into under this PPP Agreement;
- 1.2.2 references to “indexed to CPIX” in relation to any amount of money shall mean that such amount has been expressed in October 2008 prices and shall be escalated annually as at the Operation Commencement Date and each anniversary thereof at the rate reflected in the then most recent publication of the CPIX;
- 1.2.3 references to “Parties” shall include the Parties’ respective successors-in-title and, if permitted in this PPP Agreement, their respective cessionaries and assignees;
- 1.2.4 references to a “person” shall include an individual, firm, company, corporation, juristic person, Responsible Authority, and any trust, organisation, association or partnership, whether or not having separate legal personality;
- 1.2.5 references to any “Responsible Authority” or any public or professional organisation shall include a reference to any of its successors or any organisation or entity, which takes over its functions or responsibilities;
- 1.2.6 the headings of Clauses, sub-Clauses and Schedules are included for convenience only and shall not affect the interpretation of this PPP Agreement;
- 1.2.7 the Schedules to this PPP Agreement are an integral part of this PPP Agreement and references to this PPP Agreement shall include the Schedules;
- 1.2.8 the Parties acknowledge that each of them has had the opportunity to take legal advice concerning this PPP Agreement, and agree that no provision or word used in this PPP Agreement shall be interpreted to the disadvantage of either Party because that Party was responsible for or participated in the preparation or drafting of this PPP Agreement or any part of it;
- 1.2.9 words importing the singular number shall include the plural and vice versa, and words importing either gender or the neuter shall include both genders and the neuter;
- 1.2.10 references to “this PPP Agreement” shall include this PPP Agreement and its Schedules as amended, varied, novated or substituted in writing from

time to time;

1.2.11 references to any other contract or document shall include (subject to all approvals required to be given pursuant to this PPP Agreement for any amendment or variation to or novation or substitution of such contract or document) a reference to that contract or document as amended, varied, novated or substituted from time to time;

1.2.12 general words preceded or followed by words such as “other” or “including” or “particularly” shall not be given a restrictive meaning because they are preceded or followed by particular examples intended to fall within the meaning of the general words;

1.2.13 when a number of days are prescribed in this PPP Agreement, such number shall be calculated including the first and excluding the last day, unless the last day falls on a day that is not a Business Day, in which case, the last day shall be the first succeeding day which is a Business Day.

## **2. INTRODUCTION**

2.1 SANParks has the authority, power, control and responsibility in respect of the Skukuza Airport, in terms of the provisions of the Act.

2.2 SANParks wishes to expand the income generation potential of the Kruger National Park by granting a PPP for the operation and management of the Skukuza Airport as a Category 4 or 5 airport in a quest to make the park more accessible to visitors.

2.3 The Skukuza Airport requires upgrading to be operated as the relevant category (4 or 5, as determined by the Bid Submission).

2.4 SANParks' adjudication process aims to identify an appropriate and reputable Private Party in relation to the operation and management of the Skukuza Airport. The Private Party should be able to operate and manage the Skukuza Airport in accordance with Good Industry Practice and in line with the Private Party's Bid Submission. The Private Party is also to comply with any Regulatory Provisions, including licences that would in general be required from a company that manages an airport of the proposed category.

2.5 In terms of the Act, SANParks wishes to appoint the Private Party and the Private Party accepts the appointment to undertake the Project as a PPP and on the

terms and conditions of this PPP Agreement.

- 2.6 Accordingly, the Parties wish to enter into an agreement on the terms and conditions detailed below.

### **3. PROJECT TERM**

The Project Term shall commence on the Operation Commencement Date, and shall continue thereafter for a period of ten (10) years, or until the Termination Date, whichever occurs first.

### **4. STATUS OF THIS PPP AGREEMENT**

- 4.1 Notwithstanding the covenants provided in Clause 8, each Party hereto hereby represents and warrants that on and after the Signature Date this PPP Agreement is legally valid and binding upon it.
- 4.2 The Private Party will be responsible for all taxes of general application and without limiting the generality of the foregoing, any duties, fees or taxes assessed by any Relevant Authority in respect of the operation of the Skukuza Airport. These taxes will include municipal property rates, if any, in respect of the Skukuza Airport, but exclude any capital gains tax, income tax, or other taxation on income which is earned by SANParks and, notwithstanding this PPP Agreement, any other tax payable by SANParks.
- 4.3 This PPP Agreement imposes binding obligations upon the Parties and sets out the terms on which SANParks agrees that the Private Party may manage and operate the Skukuza Airport.

### **5. PPP RIGHTS**

#### **5.1 Exclusive Grant of PPP Rights**

- 5.1.1 Subject to the terms of this PPP Agreement, the PPP Rights for the purposes of the Project (at Skukuza Airport) are granted by SANParks to the Private Party on an exclusive basis during the Project Term.
- 5.1.2 During the period of this agreement, SANParks undertakes :

- 5.1.2.1 not to establish another airport that allows for the landing of scheduled aircraft within the immediate surroundings of the Skukuza Airport. For avoidance of doubt the immediate surroundings will include the Maroela Region of the Protected Area (as per the boundaries that exist on signature date);
- 5.1.2.2 not to grant to any third parties the rights referred to in 5.1.2.1 and to ensure that no third party operates or establishes any such facilities referred to in Clause 5.1.2.1.
- 5.1.3 The Private Party is obliged to operate and manage the Skukuza Airport as a public facility, open to all visitors to the Protected Area, and shall not be permitted to bar entrance to the public except in instances where the public poses a security risk and where the CAA requires such action.
- 5.1.4 Rights to operate and manage the shop and retail component contained within the Skukuza Airport building are excluded from the PPP Rights. The Parties do not exclude the possibility of agreement being reached regarding same in due course.

## 5.2 **Skukuza Airport Rights**

- 5.2.1 The grant of the PPP Rights to the Private Party shall entitle and oblige the Private Party to:
  - 5.2.2 the exclusive right to manage and operate the Skukuza Airport for gain for the duration of the PPP Agreement and to:
    - 5.2.2.1 conduct and manage all facets of the Project and to operate, manage and maintain the Skukuza Airport, infrastructure and/or equipment used for or in connection with the Project;
    - 5.2.2.2 generate, charge and collect revenues from the execution of such PPP Rights;
    - 5.2.2.3 the obligation to use the Skukuza Airport in accordance with the terms of this PPP Agreement;
    - 5.2.2.4 to purchase such Sale Assets through a Sale of Business agreement as listed in SCHEDULE 7 – SALE ASSETS. The parties record that should no such assets be listed, the Private Party will not be obliged to purchase

any such assets;

- 5.2.2.5 to source and train staff for the airport, in order to perform the duties that are expected from the Private Party as per this agreement. The parties record that no staff employed by SANParks prior to the Operation Commencement Date will be transferred to the Private Party in terms of Section 197 of the Labour Relations Act;
- 5.2.2.6 be afforded access to the Protected Area and access for the Private Party's employees, subject to the normal Protected Area's operating rules and hours on the same basis as SANParks' employees;
- 5.2.2.7 effect the changes to the Airport Facilities as per the Private Party's Bid Submission, in order to upgrade the Skukuza Airport to the relevant category airport;
- 5.2.2.8 undertake the purchases of equipment, refurbishment and infrastructural development as per the Capital Investment proposed to in the Private Party's Bid Submission and detailed in SCHEDULE 13 – CAPITAL EXPENDITURE PLAN in order to upgrade the Skukuza Airport to the relevant category airport; and

all of which rights shall be exercised in accordance with the terms of this PPP Agreement, and subject to the Regulatory Provisions, Environmental Laws, Environmental Specifications and Legislation.

### 5.3 **Service Delivery**

The Private Party shall be obliged to:

- 5.3.1 Undergo all the administration tasks to reclassify the airport from the existing category 2 to category 4 or 5 (dependent on Bid Submission);
- 5.3.2 Obtain and retain all relevant Airport Operating licences as required by the CAA;
- 5.3.3 Source scheduled flights into the Skukuza Airport (on average at least 90 seats per day inbound and 90 seats per day outbound. Average to be determined over a week period);
- 5.3.4 Manage all flights in line with approved flight paths;
- 5.3.5 Manage aircraft that land at the Skukuza Airport. Aircraft with an ACN > 16 should

not be allowed to land at the Skukuza Airport – as per SCHEDULE 18 – PCN CALCULATION REPORT.

- 5.3.6 Manage SANParks' aircraft in line with the SMAOM (to be drafted by SANParks in consultation with the Private Party);
- 5.3.7 Ensure the NDB Beacon (Non-Directional radio Beacon) is switched on and operational. If it is not operational, the Private Party shall effectively communicate with the SANDF and facilitate maintenance tasks in order to ensure that the NDB Beacon is operational;
- 5.3.8 Implement information communication system to incoming aircrafts in order to prevent fly over by pilots to determine conditions prior to landing. This might include a weather station as per CAA regulations;
- 5.3.9 Provide the booking system and all arrival and departure services for passengers;
- 5.3.10 Provide all baggage handling services;
- 5.3.11 Provide facilities in order to allow for universal accessibility of the airport;
- 5.3.12 Comply with all relevant aviation statutory requirements;
- 5.3.13 Ensure that agreements with third parties are in place that will contribute to exceptional service delivery. Such agreements include, but are not limited to, agreements with service providers for all services required to be rendered in respect of the relevant category airport in terms of CAR, CATS-AH and relevant aviation statutory requirements, the SANDF (NDB beacon), fuel supply, AVIS (car rental), the carrier responsible for scheduled flights, ground transport and shuttle service providers and various charter companies;
- 5.3.14 Negotiate on SANParks' behalf preferred rates for fuel from the fuel provider, in the event that SANParks is not the fuel provider;
- 5.3.15 Render the service according to the AOM and OEMG;
- 5.3.16 Ensure that the operating times are honoured. Unless otherwise agreed by SANParks scheduled flights will only be allowed to land and depart between 10h30 and 13h30, with private aircraft (chartered flights) landing and departing between 09h00 and 15h00;
- 5.3.17 Ensure that the total movements of 140 per week (excluding SANParks



management aircraft) are not exceeded. In total a maximum of 70 flights (excluding SANParks aircraft) will be allowed per week (70 landings and 70 departures). The Private party should also ensure that the maximum of 5 scheduled flights per day with a maximum of 21 scheduled flights per week is adhered to;

5.3.18 Render a service of an acceptable standard and quality comparable to similar standards and quality found at similar airports outside of the Protected Area;

5.3.19 Continuously revise aircrafts used to fly into Skukuza Airport in order to ensure that maximum passengers are brought into the park (within flight guidelines) with lowest noise, visual and emission / pollution impacts; and

5.3.20 In all respects comply with SCHEDULE 3 – PRIVATE PARTY OPERATIONAL REQUIREMENTS.

## **6. OPERATION, MANAGEMENT AND MAINTENANCE**

### **6.1 Operation, Management and Maintenance by the Private Party**

6.1.1 The Private Party shall be obliged to make alterations to the Skukuza Airport building in line with the proposed category airport. All the alterations and developments undertaken by the Private Party should take place according to Best Industry Practice during the hours specified by SANParks and should be completed prior to the Operation Commencement Date.

6.1.2 The Private Party shall furnish SANParks with a half-yearly report in an agreed format regarding the Operation, Management and Maintenance of the Skukuza Airport Facility.

6.1.3 The Private Party should at all times ensure that the Airport and Airport building is well maintained (as far as the Private Party's area of responsibility goes). In the unlikely event that the parties disagree on whether or not the Skukuza Airport is well maintained, the parties may revert to informal dispute resolution as per Clause 29.

6.1.4 The Private Party shall comply with the Environmental Specifications set forth in SCHEDULE 9 – ENVIRONMENTAL SPECIFICATIONS FOR THE OPERATION OF THE SKUKUZA AIRPORT WITHIN THE PROTECTED AREAS.

6.1.5 The Private Party shall:

6.1.5.1 operate the Airport Facilities properly and strictly in accordance with the

provisions of the Private Party's operating manuals and specifically the AOM and the undertakings made by the Private Party in its Bid Submission, specifically acknowledging and taking the unique characteristics of the Protected Area and stakeholders such as concession lodges and neighbouring lodges into account;

- 6.1.5.2 use its best endeavours to maintain the highest standards in accordance with Good Industry Practice in all matters connected with the operation and management of the Skukuza Airport.
- 6.1.5.3 at all times maintain the fire fighting, safety and other associated equipment used at the Skukuza Airport in a functional, orderly and working condition;
- 6.1.5.4 shall ensure that all personnel and staff employed by the Private Party at the Skukuza Airport shall at all times be clean, cleanly and tidily clothed so as to maintain uniformly high standards of presentation and delivery;
- 6.1.5.5 be responsible to inspect the airport fence daily, ensure integrity and ensure functionality of the fence (also electrical fence). Where repairs are required the Private Party will need to call for assistance from the SANParks Technical Services who will erect the repairs at SANParks' cost;
- 6.1.5.6 In the case where animals need to be removed or where the fence needs to be prepared, the Local Ranger should be called to resolve the situation.
- 6.1.6 SANParks shall conduct regular quality audits to ensure that the Skukuza Airport is managed as per the OEMG and as per the AOM. The Private Party is also responsible to ensure that pilots that use the airport abide with the rules and flies in according to the flight paths as outlined in SCHEDULE 17 – FLIGHT PATHS. Should the Private Party not be able to enforce this, the Private Party will be in default as per Clause 24.
- 6.1.7 In circumstances where the Private Party contracts with an independent third party as a franchisee or sub-concessionaire, the Private Party will remain responsible for ensuring the quality standard required by SANParks.

## 6.2 **Unauthorised Payments**

The Private Party shall not:

- 6.2.1 offer or give or agree to give any person in SANParks' employment, any gift or consideration of any kind as an inducement or reward for doing or forbearing to do or for having done or forborne to do any act in relation to the execution of this or any other contract or agreement or for showing or forbearing to show favour or disfavour to any person in relation to this or any other contract or agreement for SANParks;
- 6.2.2 enter into this or any other contract or agreement with SANParks in connection with which commission has been paid or agreed to be paid by any person, either personally or on such person's behalf, or to their knowledge, unless before that agreement is made, particulars of such commission and of the terms and conditions of any agreement for the payment thereof, have been disclosed in writing to SANParks; and
- 6.2.3 earn any secret commission in respect of any of its rights and obligations in terms of this PPP Agreement.

### 6.3 **Third Party Contracts**

The Private Party may use a third party or third parties to carry out all or part of its Operation, Management and Maintenance obligations under this PPP Agreement. Any such sub-contract shall be an Associated Agreement and the terms of any such sub-contract shall in all material respects reflect the relevant provisions of this PPP Agreement and be subject to the prior written notification and delivery of a copy of the relevant contract to SANParks, provided that the engagement of a third party shall not release the Private Party from any of its obligations hereunder.

## 7. **LABOUR LAWS**

- 7.1 The Private Party agrees to abide by the laws in force, as amended from time to time, relating to employees engaged in the business of operating an airport and shall use its best endeavours to take all reasonable steps to ensure similar compliance by its contractors, sub-contractors at all levels, assignees and agents, and furthermore agrees to adhere to and ensure, as far as practicably possible, adherence to fair labour practices.
- 7.2 The Private Party shall enter into a separate Housing Rental Agreement with SANParks in respect of the housing of staff of the Private Party.

## 8. PRIVATE PARTY COVENANTS

8.1 Subject to the provisions of this PPP Agreement, the Private Party shall conduct and manage the Project:

8.1.1 at its own cost and risk;

8.1.2 in compliance with all applicable Regulatory Provisions and consents;

8.1.3 in compliance with all applicable health and safety standards; and

8.1.4 in accordance with Good Industry Practice.

8.2 The Private Party shall take all reasonable steps to ensure that all the Private Party Parties, employees, contractors, assignees, employees, guests, invitees and patrons visiting or working at the Skukuza Airport, adhere to, abide by and comply with:

8.2.1 all Regulatory Provisions, the Environmental Specifications in respect of the Protected Area and specifically in respect of the Skukuza Airport;

8.2.2 in line with the terms of this PPP Agreement; and

8.2.3 any valid and enforceable directives or rules issued by the Park Manager from time to time. In cases where the Private Party believes that the Park Manager has issued a directive or rule that is either not valid, or that impacts materially on the commercial soundness of the Project, the Private Party shall have the right to appeal against such rule or directive with SANParks and/or any other person determined by SANParks, at its absolute sole discretion. SANParks and/or such other person determined by SANParks will verify whether the directive or rule in question was valid and consistent with practice elsewhere in the Park. Pending the results of such an appeal, the Private Party shall abide by the said directive or rule.

8.3 The Private Party shall be responsible for:

8.3.1 obtaining and keeping current all consents which may be required for the performance of its obligations under this PPP Agreement;

8.3.2 implementing each consent within the period of its validity in accordance with its terms;

8.3.3 undertaking, according to the terms of this PPP Agreement, all of its obligations

within the time periods specified; and

- 8.3.4 maintaining and keeping the Skukuza Airport Facilities clean including the area of responsibility described in SCHEDULE 1 - DESCRIPTION OF THE SKUKUZA AIRPORT FACILITIES hereto.
- 8.4 Without prejudice to Clauses 8.3.1 and 8.3.2, the Private Party shall obtain and retain all necessary permits, approvals and/or licences in accordance with the Regulatory Provisions and shall comply with all conditions of any permit, approval or licence granted by any Relevant Authority and shall take all other necessary action required under the relevant Regulatory Provisions governing all facets of the conduct of the Project during the Project Term.
- 8.5 The Private Party shall bear all risks and costs with respect to material damage to the Skukuza Airport or the environment caused by the operation of the Skukuza Airport during the Project Term arising from any act or omission of the Private Party.
- 8.6 The Private Party shall take all reasonable steps in the performance of its obligations hereunder to prevent and limit the occurrence of any environmental or health hazards and to ensure the health and safety of staff, guests, invitees and patrons.
- 8.7 The Private Party shall, upon the written request of SANParks, and at no cost to SANParks, make available at all times documents which are or were required or brought into existence by the Private Party or supplied to the Private Party by other parties to the Associated Agreements for the purposes of operating the Skukuza Airport, or which the Private Party is required to prepare in terms of this PPP Agreement.
- 8.8 Unless otherwise agreed in writing by SANParks, the Private Party and other parties to the Associated Agreements shall have no interest in nor receive remuneration in connection with the Skukuza Airport except as provided for in the PPP Agreement or the Associated Agreements.
- 8.9 At the end of the Project Term or at such earlier time as may be provided herein, the Private Party shall hand over the Skukuza Airport, all Sale Assets and New Project Assets, subject to the provisions of Clause 18, and its rights or interest in the Skukuza Airport, to SANParks free of charges, liens, claims or encumbrances of any kind whatsoever, and free of any liabilities, in good condition, fair wear and

tear excepted, in accordance with the standards set out in SANParks' Operational Requirements (as certified by SANParks) and the Sale of Business. The Private Party shall not, other than as provided for in Clause 18, in respect of the market value of the Sale Assets and New Project Assets, be entitled to payment of any compensation in connection therewith. Market value will, in the absence of agreement, be determined on the same basis as set out in Clause 18.7 hereof.

## 9. COMMERCIAL BRANDING

- 9.1 The Private Party shall not, in the operation, promotion or marketing of the Skukuza Airport, be entitled to use, directly or indirectly, any commercial branding similar to any branding used outside of the Protected Area by the Private Party, or any of its associated companies or competitors, without the prior written consent of SANParks;
- 9.2 Any commercial branding developed by the Private Party in respect of the Skukuza Airport may not be used outside the Protected Area without SANParks' prior written consent; and
- 9.3 The use of any branding, logo, trademark, trade name, get up, signage, outdoor advertising, livery, promotion, promotional or marketing material or other proprietary intellectual property in connection with the Skukuza Airport shall require the prior written approval of SANParks

## 10. PROJECT SITE

### 10.1 Skukuza Airport

The location and physical boundaries of the Skukuza Airport shall be the areas defined in SCHEDULE 1 - DESCRIPTION OF THE SKUKUZA AIRPORT FACILITIES and SCHEDULE 2 – SITE DRAWINGS OF SKUKUZA AIRPORT.

### 10.2 Access Following Commencement

With effect from the Operation Commencement Date, SANParks shall grant to the Private Party and shall use all reasonable endeavours to ensure that for the duration of the Project Term the Private Party and the Private Party Parties have such access to the Skukuza Airport as is required by the Private Party for the carrying out of the Project therein, but subject always to the provisions of this PPP

Agreement.

### 10.3 **Suitability and Condition of the Skukuza Airport**

Except for the runway at Skukuza Airport SANParks makes no representation and gives no warranty to the Private Party in respect of the condition and suitability of the Skukuza Airport or any structures associated therewith or located therein, for the Project, and the Private Party accepts the Skukuza Airport and structures at the Airport in their present condition and subject to all defects.

In terms of the runway at the Skukuza Airport, SANParks has undertaken specialist studies in order to determine the maximum ACN of aircrafts that can land at the airport. The full report forms part of this agreement – refer SCHEDULE 18 – PCN CALCULATION REPORT.

## 11. **HANDOVER**

11.1 It is a fundamental requirement by SANParks that the transfer of the Skukuza Airport is undertaken on the basis that:

11.1.1 there is no or minimal disruption in the provision of goods and services to visitors to the Park;

11.1.2 any structural alterations do not cause the Skukuza Airport to be closed totally at any time and shall be completed prior to the Operation Commencement Date;

11.1.3 the handover shall be undertaken in such a manner to cause the least disruption and/or intrusion to SANParks, employees and visitors and then only in a manner which is mutually acceptable to both SANParks and the Private Party;

11.1.4 no decisions of any direct material import relating to the operation of the business will be taken without the prior written approval of the Private Party; and

11.1.5 the business of the Skukuza Airport will be conducted in the usual manner throughout the Handover Period (operations to include chartered flights and SANParks Management aircraft landing at the airport).

11.2 During the Handover Period:

11.2.1 the Private Party and SANParks shall co-operate and work together to achieve an effective transfer of the Skukuza Airport on the Operation Commencement Date .

Specifically, the Private Party and SANParks shall co-ordinate their activities in terms of the Sale of Business in order to ensure that all these activities are undertaken and completed during the Handover Period;

- 11.2.2 SANParks shall retain responsibility for all operations, and expenses thereof, relating to the Airport Facilities during the handover period;
- 11.2.3 the Private Party shall be entitled to nominate representatives to be stationed at Skukuza, to work with SANParks management to effect a smooth handover. The Private Party's representatives shall however have no authority in relation to SANParks operations or employees during the Handover Period.
- 11.2.4 Upon completion of the alterations to the airport building the Private Party shall supply SANParks with copies of as-built drawings and other technical and design information and completion records relating to the finished works undertaken by the Private Party.
- 11.3 On the Operation Commencement Date, the Private Party shall assume full responsibility under this PPP Agreement for the operations, and expenses thereof, relating to the Skukuza Airport, and be entitled to the benefits hereof.

## **12. THE ENVIRONMENT**

- 12.1 To the extent that the Private Party needs to construct infrastructure, buildings or any other structures to support the carrying out of the Project, which pursuant to the relevant Regulatory Provisions requires an EIA, the Private Party shall not commence such construction until SANParks is satisfied that the said EIA has been undertaken in compliance with the relevant Regulatory Provisions and to the satisfaction of that authority.
- 12.2 During the Project Term, the Private Party shall conduct, manage and carry out the Project at all times in an Environmentally responsible way and as per the OEMG by adopting appropriate operating methods and practices for conducting such a Project in a proclaimed National Park and shall adhere to the Regulatory Provisions and the Environmental Specifications.
- 12.3 The Private Party shall promptly bring to the attention of SANParks any matter which may, in its view, have a detrimental impact on the Environment as a result of operations at the Skukuza Airport within the Protected Area.



- 12.4 The Private Party shall take all reasonable steps in the conducting of the Project to prevent and limit the occurrence of any Environmental or health hazards and to ensure the health and safety of the Private Party Parties and the general public.
- 12.5 The Private Party shall comply with its statutory duties in terms of the Environmental Laws to take reasonable measures to prevent pollution or degradation from occurring, continuing or recurring or, in so far as such harm to the Environment is authorised by SANParks, the findings of the EIA or by law, to minimise and rectify such pollution or degradation of the Environment.

### **13. SANPARKS' REMEDIAL RIGHTS**

Without prejudice to SANParks' rights hereunder and at law, if the Private Party fails to perform its obligations and responsibilities in accordance with this PPP Agreement or the Regulatory Provisions, SANParks may give the Private Party notice thereof and, if any such failure is not remedied within 14 (fourteen) Business Days (or such longer period as SANParks may, in its sole discretion, specify), SANParks shall be entitled to remedy such failure and to protect its rights and interests, at the expense of the Private Party which shall promptly make payment to SANParks for its costs, expenses or other damages suffered or incurred or reasonably expected to be suffered or incurred in connection with such remedial acts.

### **14. SANPARKS' UNDERTAKINGS AND RESPONSIBILITIES**

- 14.1 All decisions, determinations, instructions, inspections, examinations, tests, consents, approvals, certifications, expressions of satisfaction, acceptances, agreements, exercises of discretion (whether sole or otherwise), nominations or similar acts of SANParks hereunder shall be given, made and done in writing.
- 14.2 SANParks could, should SANParks so wish, package tourism products that will include SANParks' accommodation, which packages could make the Skukuza Airport and the use thereof more popular.
- 14.3 SANParks will co-operate with and assist the Private Party in whatever reasonable manner possible to ensure the viability of the Skukuza Airport and will not engage in acts or omissions which may materially affect the rights or interests of the Private Party in respect of the Skukuza Airport.

- 14.4 SANParks will operate and manage the Protected Area and will promote it in such manner as to ensure the continued viability and sustainability of the Protected Area as a National Park and as a sustainable and attractive tourist and conservation undertaking.
- 14.5 SANParks' procurement processes both in relation to the Skukuza Airport and in relation to the conduct of this tender and the conclusion of relevant agreements comply to the best of SANParks knowledge and belief in all material respects with:
- 14.5.1 all relevant legislation, regulations and the like governing such procurement processes;;
- 14.5.2 all current labour agreements, covenants and the like whether with individual employees or with employee organisations;
- 14.5.3 all material documentation and information relating to all aspects of the tender, the PPP Agreement have been disclosed and made available to any interested party and that all such documentation and information is accurate, correct and complete;
- 14.5.4 SANParks will be responsible for the cutting of grass surrounding the runway;
- 14.5.5 SANParks will be responsible for all external maintenance to the airport buildings;
- 14.5.6 SANParks will be responsible for the maintenance of the fence. However, the Private Party will be responsible to inform SANParks of areas that require maintenance.
- 14.5.7 SANParks will be responsible to remove animals that breached the fence. However, the Private Party will be responsible to inform the Local Ranger of such animal incidents.
- 14.5.8 With regards to universal access SANParks will, as soon as the operator finalised the plans for internal changes, make universal access changes (ramps into and out of the airport building) and change one toilet into a unisex universal access toilet. SANParks will also be responsible for the tiling of the airport building floor. The maximum amount that SANParks will spent on this will be R 226,000;
- 14.5.9 SANParks will be responsible for maintenance to the NDB terrain;
- 14.5.10 SANParks will be responsible to manage the hangers and fuel drum storage area; and
- 14.5.11 SANParks will be responsible to manage the electricity generator equipment

and facility.

- 14.6 All material documentation and information relating to all aspects of the tender and the PPP Agreement have been disclosed and made available to any interested party and all such documentation and information is accurate, correct and complete.

## 15. BLACK ECONOMIC EMPOWERMENT

- 15.1 The Private Party shall ensure compliance with all Regulatory Provisions relating to Black Economic Empowerment and undertakes to implement the BEE Obligations set out in SCHEDULE 5 – BEE OBLIGATIONS.
- 15.2 If the Private Party fails to implement its BEE Obligations in accordance with this PPP Agreement, SANParks may give the Private Party notice thereof and, if any such failure is not remedied within 14 (fourteen) Business Days (or such longer period as SANParks may, in its sole discretion, specify), SANParks shall be entitled to terminate this PPP Agreement in accordance with its terms.

## 16. FINANCIAL PROVISIONS AND PAYMENT

### 16.1 Gross Revenue

- 16.1.1 For the purposes of this PPP Agreement and its Schedules, Gross Revenue shall be defined as:

16.1.1.1 any and all income or revenue received by or accruing to the Private Party, its Subcontractors or its cessionaries and successors-in-title from all activities carried on at or by virtue of the Project, in any manner, directly or indirectly, as is or would normally be included in gross revenue in terms of GAAP and including the deemed value of any payments or benefits received by the Private Party that take a form other than a monetary form. Without derogating from its generality, the term “gross revenue” shall mean revenue before the deduction of:

16.1.1.1.1 bad debts (or provisions therefore);

16.1.1.1.2 commissions or similar consideration paid or payable;

- 16.1.1.1.3 cash, credit-card or similar discounts or commissions;
- 16.1.1.1.4 costs and expenses other than trade discounts granted in circumstances that are not arm's-length or to a related party;
- 16.1.1.2 and gross revenue shall include:
  - 16.1.1.2.1 commissions received or receivable;
  - 16.1.1.2.2 rentals and other fees received or receivable;
- 16.1.1.3 but shall exclude:
  - 16.1.1.3.1 sales tax, value-added tax and any other similar impost levied on gross revenue (or any of its components) that is normally included in or added onto the tariffs or prices charged to guests or customers and which is not normally included in gross revenue in terms of generally-accepted accounting practice;
  - 16.1.1.3.2 interest received or receivable;
  - 16.1.1.3.3 the proceeds of, profit or surpluses on the disposal of non-current assets;
  - 16.1.1.3.4 transfers from reserves; and
  - 16.1.1.3.5 bad debts recovered.

## 16.2 **PPP Fees**

- 16.2.1 The monthly PPP Fees payable by the Private Party to SANParks shall be the higher of the following two figures:
  - 16.2.1.1 the Minimum PPP Fee; or
  - 16.2.1.2 the Variable PPP Fee
- 16.2.2 The Variable PPP Fee will be calculated on the turnover for all operations at the Skukuza Airport and is listed in SCHEDULE 6 – PPP FEE.
- 16.2.3 The monthly Minimum PPP Fee and the Variable PPP Fee are set out in detail in SCHEDULE 6 – PPP FEE attached hereto. Irrespective of which these elements determines the final amount payable in any given month, the PPP Fee payment will

be the higher in any given month of the Minimum PPP Fee or the Variable PPP Fee as listed in SCHEDULE 6 – PPP FEE and shall accrue and be payable by the Private Party to SANParks within 7 (seven) Business Days following the end of each month, free of deduction or set-off, to SANParks.

16.2.4 The Private Party shall cause its auditors to audit its Gross Revenue, as determined in accordance with this PPP Agreement, and the Variable PPP Fee, on an annual basis. If any audit of the Private Party's accounts for the relevant Project Year revises the Gross Revenue on which the Variable PPP Fee is based, the difference will be paid by the Private Party to SANParks or refunded by SANParks to the Private Party, within 14 (fourteen) Business Days of the publication of the audited financial statements, in the case of the Private Party, and in the case of SANParks, within 14 (fourteen) Business Days of SANParks being furnished with such statements. Any repayment by SANParks is subject thereto that it is not obliged to repay any amount over and above the Minimum PPP Fee.

16.2.5 All PPP Fees or other amounts payable by the Private Party to SANParks in terms of this PPP Agreement shall be exclusive of value-added tax (VAT).

16.2.6 The Private Party shall, notwithstanding any other provision of this PPP Agreement, not be obliged to pay any fee for the period from the Effective Date up to the Operation Commencement Date, where after PPP Fees will be payable as provided for herein.

16.3 Notwithstanding that all consideration payable hereunder shall be deemed to be exclusive of value added tax payable in terms of the the Vat Act", and any other rates, taxes, duties, charges or imposts which may be or become payable thereon, the Private Party shall be obliged, at all times, to pay value added tax, as required by the VAT Act.

All payments to be made to SANParks by the Private Party in terms of this PPP Agreement will be made free of set-off or any other deductions whatsoever.

## 17. PERFORMANCE BOND

17.1 The Private Party shall provide to SANParks an on demand guarantee (the "Performance Bond"), which shall be operative from the Effective Date, in favour of SANParks issued by a bank or financial institution acceptable to SANParks

substantially in the format specified in SCHEDULE 12 – PERFORMANCE BOND.

- 17.1.1 The Private Party shall maintain a valid Performance Bond (in accordance with the provisions hereof) from the Effective Date until 90 (ninety) Business Days after the expiry or earlier termination of this PPP Agreement.
- 17.1.2 Within 90 (ninety) Business Days of the Expiry Date or earlier termination of this PPP Agreement, SANParks shall release all or so much of the Performance Bond as shall remain undrawn after such expiry or termination.
- 17.1.3 The amount to be guaranteed by the Performance Bond for the first twelve month period as from the Effective Date shall be the equivalent of 3 (three) months Minimum PPP Fees.
- 17.1.4 The Performance Bond shall be reinstated in full and its amount adjusted annually within 90 (ninety) Business Days of the end of each Project Year such that the amount to be guaranteed by the Performance Bond for the relevant Project Year is not less than the figure indicated in Clause 17.1.3 as adjusted to reflect changes in the Consumer Price Index since Bid Submission.
- 17.1.5 The Performance Bond shall secure the Private Party's performance under this PPP Agreement and may be called on by SANParks to the extent of any costs, losses, damages or expenses suffered or incurred by SANParks as a result of breach by the Private Party of this PPP Agreement, including, but not limited to, compensation to SANParks for any actions taken by SANParks as a result of breach by the Private Party of any Regulatory Provision(s), Laws, Legislation or Environmental Specifications and payment obligations hereunder. The Performance Bond may also be called upon for any delay in the payment of sums due to SANParks in respect of PPP Fee payments.
- 17.1.6 Prior to enforcing the Performance Bond, SANParks shall give notice to the Private Party, informing the Private Party of the breach giving rise to the right of enforcement of the Performance Bond. If such breach is not remedied within the remedy period, SANParks may enforce the Performance Bond.
- 17.1.7 The Performance Bond may only be enforced to the extent of any costs, losses, damages or expenses suffered or incurred and/or reasonably expected to be suffered or incurred as a result of the breach that gave rise to the right to enforce the Performance Bond.

## 18. SALE OF BUSINESS

### 18.1 Introduction

18.1.1 SANParks hereby sells the Business to the Private Party as a going concern with effect from the Operation Commencement Date, on which date all risks in and benefits attaching to the Business shall pass to the Private Party. The parties record that the airport is currently a category 2 airport and the Private Party will be responsible to do all the actions in order to re-classify the airport to category 4 or 5 and source in scheduled flights.

18.1.2 None of the Liabilities of the Business incurred prior to the Operation Commencement Date, nor any debtors of the Business, in respect of which the cause of action arose prior to the Operation Commencement Date, will be transferred to the Private Party but all of them will remain those of SANParks

18.1.3 It is recorded that as -

18.1.3.1 the Private Party and SANParks agree that the Business is -

18.1.3.1.1 an enterprise capable of separate operation;

18.1.3.1.2 being sold as a going concern;

18.1.3.2 SANParks and the Private Party agree that the Business will constitute an income-earning activity on the Operation Commencement Date; and

18.1.3.3 the assets and contracts necessary to carry on the Business are being disposed of by SANParks to the Private Party in terms of this agreement.

18.1.4 The sale contained in this agreement falls within the ambit of Section 11(1) (e) of the VAT Act and therefore VAT is payable at the rate of zero percent.

18.1.5 Should the South African Revenue Service rule that VAT is payable in respect of the Business or any of the Sale Assets sold at a rate exceeding zero percent, the Private Party shall pay that VAT.

18.1.6 The Private Party warrants to SANParks that on the Effective Date it will be registered as a vendor in terms of the VAT Act. The Private Party intends to carry on the Business continuously and regularly from the Operation Commencement Date and acknowledges that it reasonably expects this activity to result in taxable supplies in excess of R300 000.00 (three hundred thousand Rand) over a period of 12

(twelve) months from the Operation Commencement Date.

18.1.7 SANParks warrants to the Private Party that:

18.1.7.1 on SANParks' signature of this agreement and on the Effective Date it will be registered as a vendor in terms of the VAT Act; and

18.1.7.2 the total value of taxable supplies made by SANParks from carrying on the Business in the preceding period of 12 (twelve) months shall have exceeded R20, 000 (twenty thousand Rand).

## 18.2 **Sale Assets**

18.2.1 As part of this PPP Agreement, SANParks shall sell to the Private Party, those items of equipment and furnishings as specified in in SCHEDULE 7 – SALE ASSETS of this PPP Agreement.

18.2.2 The procedure for determining the extent and value of the Sale Assets shall be as follows:

18.2.2.1 A list of all assets will be made during the handover period;

18.2.2.2 SANParks will appoint an Agent experienced in the valuation of the equipment to determine a market value of such equipment;

18.2.2.3 At the end of the Handover Period, SANParks shall furnish the Private Party with the specified list and prices of the Sale Assets, as determined by the Agent appointed in terms of Clause 18.2.2.2, such list to be attached as SCHEDULE 7 – SALE ASSETS.

18.2.2.4 The ownership of the Sale Assets included in SCHEDULE 7 – SALE ASSETS shall pass to the Private Party upon payment of the Purchase Price by the Private Party (refer Clause 18.3) on the Operation Commencement Date.

## 18.3 **Purchase Price**

The Purchase Price payable by the Private Party to SANParks for the Business shall be the total amount determined as prices for the Sale Assets in accordance with Clause 18.2. Should no Sale Assets be sold to the Private Party, the Purchase Price for the Business will be the amount of R 1-00 (one Rand).



**18.4 Payment**

The Private Party shall pay the Purchase Price for the Business to SANParks by way of a certified cheque, drawn on a bank acceptable to SANParks, on the Operation Commencement Date.

**18.5 Possession**

**18.5.1 On the Operation Commencement Date –**

18.5.1.1 SANParks shall place the Private Party in possession of the Business and the Sale Assets at the Skukuza Airport; and

18.5.1.2 the risk in and benefit attaching to the Business (including ownership of the Business and the Sale Assets) shall pass to the Private Party.

18.5.2 Signature by SANParks and the Private Party of this agreement shall constitute, with effect from the Operation Commencement Date, delivery to the Private Party of all of SANParks' rights in the Business and no further formalities shall be required to give effect to such delivery.

**18.5.3 SANParks undertakes that until the Operation Commencement Date it will –**

18.5.3.1 not pledge or otherwise encumber nor alienate, sell or otherwise dispose of any of the Sale Assets;

18.5.3.2 not remove or permit the removal of any of the Sale Assets from the Skukuza Airport, other than in the normal course of Business;

18.5.3.3 continue to keep the Sale Assets in good order and condition; and

18.5.3.4 continue to insure the Sale Assets against the risk of loss or damage attributable to storm, fire, theft or riot and to also keep them insured under the equivalent of an “all risks” policy over them which covers them while they are not at the Skukuza Airport.

**18.6 Debtors**

The Parties hereby record that all debts owed to the Business as at the Operation Commencement Date shall be collected by and be for the account of SANParks.

**18.7 Automatic Buy-Back**

18.7.1 SANParks shall, subject to the provisions of Clause 26 and Clause 25.3, at the termination of this agreement for whatever reason, be entitled to re-purchase the Business, including the Sale Assets and New Project Assets, as a going concern, for a consideration equal to the market value at that time, subject to the provisions of Clause 18.7.3, of the Sale Assets and the New Project Assets, mutatis mutandis on the same terms and conditions as those contained in this agreement, fair wear and tear excepted. The market value of the Sale Assets and the New Project Assets shall be determined by a panel of 3 (three) evaluators, one to be appointed by each of the parties and a third independent evaluator, by the first two appointed evaluators.

18.7.2 The amount payable by SANParks under Clause 18.7.1 shall accrue interest at the rate specified in Clause 30.3.3 from the date of termination to the due date for payment as specified in Clause 30.3.

18.7.3 The Parties acknowledge that the Private Party shall be entitled, for the duration of this agreement, to modify and to change, in its absolute discretion, any or all of the Sale Assets in order that such amended Sale Asset shall fulfil a different or more efficient function in the provision of services by the Private Party to SANParks, provided it does not detract from the Private Party's obligations in terms of this PPP Agreement.

18.7.4 The Private Party shall, at the termination of this agreement for whatever reason, hand over the Sale Assets and New Project Assets to SANParks, in the same condition as at the commencement of this agreement, in the instance of the Sale Assets, and in the instance of the New Project Assets, in the same condition as at date of acquisition, fair wear and tear excepted, provided that the Private Party shall be entitled to re-deliver to SANParks the Sale Assets in the state in which they shall have been modified as envisaged in terms of Clause 18.7.3 above. In the event that it shall be impractical for the Private Party to return any such Sale Assets or New Project Assets, the Private Party shall compensate SANParks in respect thereof at the market value of such Sale Assets or New Project Assets agreed by the Parties, or, in the absence of such agreement, determined by an independent valuator.

## **18.8 Insolvency Act Publication**

18.8.1 The Parties agree that notice of this transaction will not be published as contemplated in section 34 of the Insolvency Act, 1936 (Act No. 24 of 1936) (as amended) (the "Insolvency Act").

18.8.2 SANParks indemnifies the Private Party against any loss or damage which

the Private Party may suffer as a result of notice of this transaction not being published in terms of the Insolvency Act.

**18.9 Voetstoots**

The Business is sold voetstoots and the Private Party accepts that SANParks gives no warranties in regard to the Business or the Sale Assets other than in respect of the condition of the runway and to the extent as outlined in SCHEDULE 18 – PCN CALCULATION REPORT as done in July 2008.

**18.10 Employees**

18.10.1 No SANParks employee who currently works at the Skukuza Airport will transfer to the Private Party in accordance with Section 197(1) of the Labour Relations Act, 1995 (Act No. 66 of 1995), (as amended). Only 1 person will remain at the airport but will continue in the employment of SANParks and will be required to collect conservation levies and perform administrative tasks at the airport on behalf of SANParks.

18.10.2 The Private Party undertakes to provide the 1 SANParks employee with office space ,at no cost to SANParks, in such a fashion that it compliments the process flow and business at the Skukuza Airport.

**19. INSURANCE**

19.1 The Private Party shall insure all insurable properties within the Skukuza Airport including the Project Assets, with a reputable insurance company by no later than the Operation Commencement Date:

19.1.1 for not less than the full replacement value of the Project Assets;

19.1.2 against the risk of fire, lightning, explosion, storm, flood, earthquake, riots (including political riot), strikes and malicious damage;

19.1.3 in respect of property and casualty insurance;

19.1.4 in respect of public liability and third party insurance in line with best practices in the aviation industry;

19.1.5 in respect of employer's liability insurance;

- 19.1.6 in respect of business interruption insurance; and
- 19.1.7 in respect of all risks cover and loss of PPP Fee for six (6) months consequent upon the damage to or destruction of the Project Assets as a result of any of the aforesaid events.
- 19.2 All premiums, subsequent renewal premiums, all additional premiums and all stamp duties in respect of the relevant insurance policies, shall be paid by the Private Party.
- 19.3 The private Party shall ensure that the interest of SANParks be noted on the policies set forth in Clause 19.
- 19.4 Should the Private Party be in breach of the provisions of Clause 19.1, SANParks may, after consultation with the Private Party and giving the Private Party thirty (30) days within which to comply with Clause 19.1, but will not be obliged to, procure and maintain, at the sole cost and expense of the Private Party, the insurances referred to in Clause 19.1 to the extent that SANParks deems necessary. In this event, the Private Party shall be obliged to refund to SANParks all premiums disbursed by SANParks on behalf of the Private Party within a period of fourteen (14) days of receiving written notice from SANParks to do so.
- 19.5 The Private Party shall comply with all the terms and conditions embodied in the insurance policy or insurance policies referred to in Clause 19 and undertake not to commit any act or permit any act to be committed or omit to do anything which in any way affects or vitiates such insurance policy or policies.
- 19.6 The Private Party shall be obliged to utilise the proceeds of any policy in respect of the damage to or destruction of any Project Asset to repair or replace such Project Asset.
- 19.7 The Private Party undertakes to provide SANParks with certified copies of the certificates of insurance and certified copies of the insurance policies within seven (7) days of the Operation Commencement Date to be attached to this PPP Agreement as SCHEDULE 11 – INSURANCE. Such certificates and policies shall reflect all insurance coverage stipulated by SANParks.

## 20. INDEMNITIES AND LIABILITY

## 20.1 Private Party Indemnity

20.1.1 The Private Party shall indemnify SANParks, and hold SANParks harmless from and shall be responsible to third parties for, any liability, loss, damage, damages, cost or costs of any kind whatsoever incurred or suffered by any third party or SANParks on or after the Operation Commencement Date, including any claim against SANParks by a Relevant Authority, as a result of any act or omission of the Private Party or any Responsible Person, (including without limitation any default or failure by the Private Party under this PPP Agreement) with regard to the operation and management of the Skukuza Airport except to the extent directly caused by any gross negligence, material default or material breach of statutory duty on the part of SANParks or such Relevant Authority.

20.1.2 Without limiting the generality of the foregoing, the Private Party shall indemnify SANParks against all liability, loss, damage, damages, cost or costs and claims by third parties against SANParks in respect of:

- 20.1.2.1 death or injury to any Person; or
- 20.1.2.2 loss of or damage to any property; or
- 20.1.2.3 any economic loss

arising out of any such act or omission by the Private Party referred to in Clause 20.1.1 above.

It is recorded that notwithstanding the provisions of Clause 20.1.1 to and including 20.1.2 each of SANParks and the Private Party shall be responsible for loss of, or damage to its own property or personal injury or death of its own employee and each party shall hold harmless the other and waive any right of recourse against the other party in respect of such loss and shall obtain the same waiver of right of recourse from its insurers. Each party shall obtain the agreement of its insurers in respect of the provisions of this Clause 20.1.2.

## 20.2 Legal Action

20.2.1 The Private Party will erect and display a clear notice at the Skukuza Airport to the effect that the Skukuza Airport is operated by an independent operator under contract from SANParks, specifying its name.

20.2.2 If any legal action is brought or claim is made against SANParks in respect of which

SANParks is entitled to be indemnified under Clause 20, the Private Party shall, if required to do so by SANParks, defend any such action or claim at its own expense or provide SANParks with full co-operation in defending such action or claim. If the Private Party defends such action or claim SANParks shall be entitled to specify which legal counsel shall be appointed and shall have the final say as to the manner in which the defence shall be conducted. SANParks may settle such action or claim without the consent of the Private Party or take over the conduct of the action from the Private Party at any time without relieving the Private Party of the obligation to indemnify SANParks under Clause 20.

## **21. GENERAL REPORTING AND FINANCIAL REPORTING REQUIREMENTS**

### **21.1 General Reporting**

21.1.1 Without detracting from its obligations in terms of Clause 11.2.4, the Private Party shall supply SANParks with all documents, drawings, data, reports, specifications and other information (whether in printed form or in electronic form) produced in respect of any alterations, amendments and/or refurbishments to the Skukuza Airport, copies of all "as-built" drawings and such other technical and design information and completion records relating to the finished work as SANParks may reasonably request.

21.1.2 From the Operation Commencement Date as well as during the Project Term, the Private Party shall provide SANParks with written reports in respect of the following matters, within 30 (thirty) Business Days of the end of each Project Year:

21.1.2.1 names, identity numbers and any other relevant details of any employees of the Private Party or its Subcontractors who are engaged in respect of the Project and who have resigned or been dismissed during the relevant Project Year, together with the details of any firearms registered to such employees;

21.1.2.2 its compliance with the Environmental Specifications as detailed in SCHEDULE 9 – ENVIRONMENTAL SPECIFICATIONS FOR THE OPERATION OF THE SKUKUZA AIRPORT WITHIN THE PROTECTED AREAS;

21.1.2.3 the Insurance provisions of Clause 19; and

21.1.2.4 it's BEE Obligations contained in SCHEDULE 5 – BEE OBLIGATIONS.

## 21.2 **Annual Financial Reporting**

The Private Party shall furnish SANParks, as soon as practicable but in any event not later than 4 calendar months after the end of each Project Year, with:

21.2.1 three (3) copies of the Private Party's complete audited financial statements for such Project Year (which are consistent with the books of accounts and prepared in accordance with GAAP), together with an audit report thereon, all in accordance with the requirements of the laws and Regulations pertaining to accounting;

21.2.2 a copy of any management letter or other communication sent by the auditors to the Private Party or to its management in relation to the Private Party's financial, accounting and other systems, management and accounts;

21.2.3 an annual report by the auditors certifying that, based on its said financial, accounting and other systems, management and accounts, the Private Party was in compliance with its financial obligations in respect of the Project as at the end of the relevant Project Year or detailing any non-compliance by the Private Party therewith;

21.2.4 a reconciliation of the current year's profit and loss account and the budget for the year, and an analysis thereof.

## 21.3 **Requests For Information**

The Private Party shall furnish such documents and information pertaining to the performance of its obligations in terms of this PPP Agreement, as SANParks may reasonably require.

## 22. **DEFAULT INTEREST**

Interest shall accrue on all overdue amounts payable in terms of this PPP Agreement at the prime overdraft interest rate charged by First National Bank of South Africa plus 2 % (two percent). Such interest shall be computed on a daily basis from the due date of payment until the relevant amount together with accrued interest is fully paid by the defaulting party.

## 23. **FORCE MAJEURE**

**23.1 Definition and Procedure**

23.1.1 For the purposes of this PPP Agreement, "Force Majeure" means any of the following events or circumstances which are beyond the reasonable control of the party giving notice of force majeure, including but not limited to:

23.1.1.1 War (whether declared or not), civil war, armed conflicts or terrorism, revolution, invasion, insurrection, riot, civil commotion, mob violence, sabotage, blockade, embargo, boycott, the exercise of military or usurped power, fire, explosion, theft, storm, flood, drought, wind, lightning or other adverse weather condition, epidemic, quarantine, accident, acts or restraints of Government imposition, or restrictions of or embargos on imports or exports; or

23.1.1.2 nuclear contamination unless the Private Party and/or any Sub-contractor is the source or cause of the contamination; or

23.1.1.3 chemical or biological contamination of the Skukuza Airport from any of the events referred to in Clauses 23.1.1.1 and 23.1.1.2 above,

that directly causes either Party to be unable to comply with all or a material part of its obligations under this PPP Agreement.

23.1.2 Subject to Clause 23.1.3, the Party claiming relief shall be relieved from liability under this PPP Agreement to the extent that it is not able to perform all or a material part of its obligations under this PPP Agreement as a result of an event of Force Majeure.

23.1.3 Where a Party is (or claims to be) affected by an event of Force Majeure:

23.1.3.1 it shall take all reasonable steps to mitigate the consequences of such an event upon the performance of its obligations under this PPP Agreement, resume performance of its obligations affected by the event of Force Majeure as soon as practicable and use all reasonable endeavours to remedy its failure to perform; and

23.1.3.2 it shall not be relieved from liability under this PPP Agreement to the extent that it is not able to perform, or has not in fact performed, its obligations under this PPP Agreement due to its failure to comply with its obligations under Clause 23.1.3.1.

23.1.4 The Party claiming relief shall serve written notice on the other Party within 15



Business Days of it becoming aware of the relevant event of Force Majeure. Such initial notice shall give sufficient details to identify the particular event claimed to be an event of Force Majeure Event.

23.1.5 A subsequent written notice shall be served by the Party claiming relief on the other Party within a further 5 (five) Business Days. The written notice shall contain such relevant information relating to the failure to perform (or delay in performing) as is available, including (without limitation) the effect of the event of Force Majeure on the ability of the Party to perform, the action being taken in accordance with Clause 23.1.3.1, the date of the occurrence of the event of Force Majeure and an estimate of the period of time required to overcome it and/or its effects.

23.1.6 The Party claiming relief shall notify the other as soon as the consequences of the event of Force Majeure have ceased and when performance of its affected obligations will be resumed.

23.1.7 If, following the issue of any notice referred to in Clause 23.1.4, the Party claiming relief receives or becomes aware of any further information relating to the event of Force Majeure and/or any failure to perform, it shall submit such further information to the other Party as soon as reasonably possible.

23.1.8 Neither SANParks nor the Private Party shall have any right to payment or otherwise in relation to the occurrence of an event of Force Majeure.

23.1.9 The Parties shall endeavor to agree any modifications to this PPP Agreement, which may be equitable having regard to the nature of an event or events of Force Majeure. Clause 29 shall not apply to a failure of the Parties to reach agreement pursuant to this Clause 23.1.9, and this PPP Agreement shall terminate in terms of Clause 23.2 if no such agreement is reached.

## 23.2 **Termination for Force Majeure**

If, in the circumstances referred to in Clause 23, the Parties have failed to reach agreement on any modification to this PPP Agreement pursuant to that Clause, within 180 days of the date on which the Party affected serves notice on the other Party in accordance with that Clause, either Party may at any time afterwards terminate this PPP Agreement by written notice to the other Party having immediate effect, provided always that the effects of the relevant event of Force Majeure continue to prevent either Party from performing any material obligation

under this PPP Agreement.

## 24. PRIVATE PARTY DEFAULT

### 24.1 Definition

**"Private Party Default"** means any of the following events or circumstances:

- 24.1.1 any arrangement, composition or compromise with or for the benefit of creditors (including any voluntary arrangement as defined in the Insolvency Act, 1936 or the Companies Act, 1973) being entered into by or in relation to the Private Party;
- 24.1.2 a liquidator, judicial manager or the like taking possession of or being appointed over, or any judicial management, winding-up, execution or other process being levied or enforced (and not being discharged within 15 Business Days) upon, the whole or any material part of the assets of the Private Party (in any of these cases, where applicable, whether provisional or final, and whether voluntary or compulsory);
- 24.1.3 the Private Party ceasing to carry on business;
- 24.1.4 a resolution being passed or an order being made for the administration or the judicial management, winding-up, liquidation or dissolution of the Private Party (in any of these cases, where applicable, whether provisional or final and whether voluntary or compulsory);
- 24.1.5 the Private Party commits a breach of any of its material obligations under this PPP Agreement, and without derogating from the generality of the foregoing, a failure to comply with any of the obligations imposed on the Private Party as set out in the Schedules to this PPP Agreement or specific clauses of the PPP Agreement that outline obligations of the Private Party shall be deemed to be a breach of a material obligation;
- 24.1.6 the Private Party breaches any of the provisions of SCHEDULE 5 – BEE OBLIGATIONS or Clause 21.1.2.4;
- 24.1.7 the Private Party fails to pay any sum or sums due to SANParks under this PPP Agreement and such failure continues for 20 Business Days from receipt by the Private Party of a notice of non-payment from SANParks;
- 24.1.8 the Private Party or any of its directors or officers is found guilty of an offence by a

court of law, unless such finding of the relevant court is the subject of an appeal that is being diligently pursued by the Private Party or its relevant director or officer (as the case may be);

24.1.9 the Private Party or any of its directors or officers falsifies any report, document or information that is provided by the Private Party to SANParks;

24.1.10 any breach of any provision of this PPP Agreement has occurred more than once and:

24.1.10.1 SANParks has given an initial warning notice to the Private Party describing that breach in reasonable detail and stating that if that breach persists or recurs then SANParks may take further steps to terminate the PPP Agreement; and

24.1.10.2 SANParks has issued a second and final warning notice following the persistence or recurrence of that breach in the period of 90 days after the initial warning notice, stating that if that breach persists or recurs within the period of 30 days after the final warning notice then SANParks may terminate the PPP Agreement on 30 days' notice to the Private Party;

24.1.11 the Private Party breaches any of the provisions relating to its financial obligations in terms of this PPP Agreement.

## 24.2 **SANParks' Options**

24.2.1 On the occurrence of a Private Party Default, or within a reasonable time after SANParks becomes aware of the same, SANParks may:

24.2.1.1 in the case of the Private Party Default referred to in Clauses 24.1.1, 24.1.2, 24.1.3, 24.1.4, 24.1.6, 24.1.7, 24.1.8, 24.1.9 and 24.1.11 terminate this PPP Agreement in its entirety by notice in writing having immediate effect;

24.2.1.2 in the case of any other Private Party Default referred to in Clauses 24.1.5 and 24.1.10, serve notice of default on the Private Party requiring the Private Party to remedy the Private Party Default referred to in such notice of default (if the same is continuing) within 20 Business Days of such notice of default.

24.2.2 If the Private Party Default is notified to the Private Party in a notice of default in

terms of Clause 24.2.1.2 and the Private Party Default is not remedied before the expiry of the period referred to in the notice, then SANParks may terminate this PPP Agreement with immediate effect by written notice to the Private Party and the Lenders.

#### 24.3 **SANParks' Costs**

24.3.1 The Private Party shall reimburse SANParks with all costs incurred by SANParks in exercising any of its rights in terms of this Clause 24 (including, without limitation, any relevant increased administrative expenses).

24.3.2 SANParks shall not exercise, or purport to exercise, any right to terminate this PPP Agreement except as expressly set out in this PPP Agreement. The rights of SANParks (to terminate or otherwise) under this Clause, are in addition (and without prejudice) to any other right which SANParks may have in law to claim the amount of loss or damages suffered by SANParks on account of the acts or omissions of the Private Party (or to take any action other than termination of this PPP Agreement).

#### 24.4 **Termination Amount on Private Party Default**

24.4.1 On termination of this PPP Agreement as a result of Private Party Default and in the event that SANParks exercises its rights under Clause 18.7, the following amounts shall be deducted from the market value of the Sale Assets and New Project Assets payable in terms of Clause 18.7:

24.4.1.1 the cost and expense incurred or to be incurred in the reinstatement of the Skukuza Airport as at date of termination, fair wear and tear accepted;

24.4.1.2 an amount equal to all damages recoverable at law;

24.4.1.3 all costs and expenses incurred and/or reasonably expected to be incurred in restoring or remedying material damage to the Skukuza Airport and the Environment caused by the Private Party and/or any Person for whom it is legally responsible in terms of this PPP Agreement; and

24.4.1.4 all reasonably foreseeable economic losses suffered or reasonably expected to be suffered by SANParks as a result of the breach or breaches by the Private Party of this PPP Agreement which resulted in termination of this PPP Agreement pursuant to Clause 24.2.2.

24.4.2 Should SANParks not exercise its rights to terminate pursuant to Clause 24.2.2, the

Private Party shall compensate SANParks for all damages, costs and expenses incurred by SANParks as a result of events set forth in Clause 24.

## 25. SANParks DEFAULT

### 25.1 Definition

"**SANParks Default**" means any one of the following events:

25.1.1 an expropriation of a material part of the Skukuza Airport and/or Project Assets of the Private Party by SANParks or other Responsible Authority; and

25.1.2 a breach by SANParks of the material obligations under this PPP Agreement which substantially frustrates or renders it impossible for the Private Party to perform its obligations under this PPP Agreement for a continuous period of 3 months.

### 25.2 Termination for SANParks Default

25.2.1 On the occurrence of an SANParks Default, or within 10 days after the Private Party becomes aware of same, the Private Party may serve notice on SANParks of the occurrence (and specifying details) of such SANParks Default. If the relevant matter or circumstance has not been remedied or rectified within 30 Business Days of such notice, the Private Party may serve a further notice on SANParks terminating this PPP Agreement with immediate effect.

25.2.2 The Private Party shall not exercise or purport to exercise any rights to terminate this PPP Agreement (or accept any repudiation of this PPP Agreement) except as expressly provided for herein.

### 25.3 Termination Amount for SANParks Default

On termination of this PPP Agreement as a result of SANParks Default, SANParks shall pay the Private Party an amount equal to the book value of the Sale Assets and New Project Assets, set out in the annual audited books of account of the Private Party on the date of such termination.

## 26. TERMINATION BY NOTICE

Prior to the expiry of the Project Term, SANParks may on written notice of not less than 6 (six) months, give the Private Party notice of termination of this PPP Agreement, in

which event this PPP Agreement shall terminate. On termination of this PPP Agreement in accordance with this Clause 26, SANParks shall pay the Private Party an amount equal to the book value of the Sale Assets and the New Project Assets, set out in the annual audited books of account of the Private Party on the date of such termination.

## 27. CORRUPT GIFTS AND FRAUD

### 27.1 Definition and Warranty

The Private Party warrants that in entering into this PPP Agreement it has not committed any Corrupt Act. Any breach of this warranty shall entitle SANParks to terminate this PPP Agreement immediately in terms of Clause 24.2.1.

"**Corrupt Act**" means:

27.1.1 offering, giving or agreeing to give to SANParks or any other organ of state or to any person employed by or on behalf of SANParks or any other organ of state any gift or consideration of any kind as an inducement or reward:

27.1.2 for doing or not doing (or for having done or not having done) any act in relation to the obtaining or performance of this PPP Agreement or any other contract with SANParks or any other organ of state; or

27.1.3 for showing or not showing favour or disfavour to any person in relation to this PPP Agreement or any other contract with SANParks or any other organ of state;

27.1.4 entering into this PPP Agreement or any other contract with SANParks or any other organ of state in connection with which commission has been paid or has been agreed to be paid by the Private Party or on its behalf, or to its knowledge, unless before the relevant contract is entered into particulars of any such commission and of the terms and conditions of any such contract for the payment of such commission have been disclosed in writing to SANParks;

27.1.5 committing any offence:

27.1.5.1 under any law from time to time dealing with bribery, corruption or extortion;

27.1.5.2 under any law creating offences in respect of fraudulent acts; or

27.1.5.3 at common law, in respect of fraudulent acts in relation to this PPP Agreement or any other contract with SANParks or any other public body;  
or

27.1.5.4 defrauding or attempting to defraud or conspiring to defraud SANParks or any other public body.

## 27.2 Termination Amount for Corrupt Gifts and Fraud

27.2.1 The Private Party shall reimburse SANParks with all costs incurred by SANParks in exercising any of its rights in terms of this Clause 27 (including, without limitation, any relevant increased administrative expenses).

27.2.2 The rights of SANParks (to terminate or otherwise) under this Clause are in addition (and without prejudice) to any other right which SANParks may have in law to claim the amount of loss or damages suffered by SANParks on account of the acts or omissions of the Private Party (or to take any action other than termination of this PPP Agreement).

## 28. CONFIDENTIALITY

Each Party shall keep all confidential information of the other Party confidential while this Agreement remains in force and for a period of 5 years after it terminates for any reason. Each Party shall also use reasonable endeavours to prevent its employees, agents and Subcontractors from making any disclosure to any person of any confidential information of the other Party while this Agreement remains in force and for a period of 3 years after it terminates for any reason.

The above shall not apply to:

28.1.1 any disclosure of information that is reasonably required by persons engaged in the performance of the restricted Party's obligations under this Agreement;

28.1.2 any matter which a Party can reasonably demonstrate is already generally available and in the public domain otherwise than as a result of a breach of this clause;

28.1.3 any disclosure as part of any attempt to resolve a dispute in accordance with clause 29;

28.1.4 any disclosure which is required by any law (including any order of a Court of

competent jurisdiction), or the rules of any stock exchange or governmental or regulatory authority having the force of law;

28.1.5 any disclosure of information that is already lawfully in the possession of the receiving Party prior its disclosure by the disclosing Party;

28.1.6 any provision of information to the advisors of the receiving Party;

28.1.7 any disclosure by the Institution of information relating to the design, construction, operation and maintenance of the Project and any other information that may be reasonably required for the purpose of re-tendering of this Agreement;

28.1.8 any disclosure of information by the Institution to any Responsible Authority;

28.1.9 any disclosure made with the prior written consent of the disclosing Party.

The disclosures permitted under clauses 28.1.6, 28.1.7 and 28.1.8 may only be made subject to obtaining appropriate confidentiality restrictions consistent with the provisions of this clause from the intended recipients.

## 29. DISPUTE RESOLUTION

### 29.1 Referable Disputes

The provisions of this Clause 29 shall, save where expressly provided otherwise, apply to any dispute arising in relation to or in connection with any aspect of this PPP Agreement between the Parties.

### 29.2 Internal Referral

29.2.1 If a dispute arises in relation to any aspect of this PPP Agreement, the Parties shall attempt in good faith to come to an agreement in relation to the disputed matter, in accordance with the following informal process:

29.2.2 all disputes shall first be referred to a meeting of the liaison officers or other designated executives from each Party who are actively involved in the Project, and have sufficient authority to be able (if necessary with consultation back to their respective organisations) to resolve it; and

29.2.2.1 if the Parties have been unable to resolve the dispute within 30 days of referral to the persons specified in Clause 29.2.2, either Party may refer



the dispute for a decision by the Accounting Officer or Accounting Authority of SANParks and the Chief Executive Officer or equivalent officer of the Private Party.

29.2.3 In attempting to resolve the dispute in accordance with the provisions of this Clause 29.2.3, the Parties shall (and shall procure that their employees and representatives shall) use reasonable endeavours to resolve such dispute without delay by negotiations or any other informal procedure which the relevant representatives may adopt. Those attempts shall be conducted in good faith in an effort to resolve the dispute without necessity for formal proceedings.

29.2.4 Any dispute which has not been resolved by the representatives contemplated in Clause 29.2.2.1 within 30 days of the dispute being referred to them (or any longer period agreed between the Parties) shall be treated as a dispute in respect of which informal resolution has failed.

### 29.3 **Performance to Continue**

No reference of any dispute to any resolution process in terms of this Clause shall relieve either Party from any liability for the due and punctual performance of its obligations under this PPP Agreement.

### 29.4 **Litigation**

29.4.1 Save where any dispute has been expressly referred for determination, if informal resolution of any dispute has failed, then the dispute may be referred to litigation in the courts by either Party.

29.4.2 Neither Party is limited in any proceedings before the court to the information, evidence or arguments used in the informal attempts to resolve the dispute.

## 30. **EFFECT OF EXPIRY OR TERMINATION**

30.1 On the expiry or termination of this PPP Agreement and/or the Project Term for whatever reason and without prejudice to any rights of the Parties hereto (subject as herein provided):

30.1.1 this PPP Agreement (other than this Clause 30 and Clauses 17, 18.7, 20, 24.3, 24.4, 25.3, 28, 29, 31, 34, 35, 36, 37, 39, 40 and 42) shall cease to have effect,

subject to all rights and obligations of the Parties existing prior to such termination

30.1.2 such rights as the Private Party may have over the Skukuza Airport, the Sale Assets, the New Project Assets and all other immovable property, shall terminate;

30.1.3 the Private Party shall deliver all documentation relating to the Skukuza Airport to SANParks.

30.2 Upon termination of this PPP Agreement, SANParks shall have the right to:

30.2.1 enter and take immediate control of the Skukuza Airport; or

30.2.2 select and substitute a new entity to take over the operation of the Skukuza Airport.

### 30.3 **Payment Procedure**

30.3.1 Except as otherwise provided for expressly in this PPP Agreement, whenever under this PPP Agreement an amount is required to be paid by any Party, such Party shall make the same available to the other Party within 5 (five) Business Days to such account with such bank in the Republic of South Africa as the other Party may have specified for this purpose.

30.3.2 Without prejudice to any other right or remedy, each Party shall be entitled to receive interest on an amount due under this PPP Agreement, at the rate referred to in Clause 22. Interest which has accrued on an amount due under this PPP Agreement shall be paid on the same date as payment of such amount.

30.3.3 For the purposes of Clause 30.3.2, interest shall accrue at a rate equal to the prime rate charged by SANParks' bankers. Such interest shall be computed on a daily basis from the due date of payment until the relevant amount together with accrued interest is fully paid by the defaulting Party.

30.3.4 All payments to be made under this PPP Agreement shall be made in Rand.

### 30.4 **Other Rights and Remedies**

30.4.1 No Party shall have any rights or remedies against any other Party arising on termination save for the rights and remedies specified in this PPP Agreement.

### 30.5 **Calculations**

30.5.1 If any forecast or calculation is required to be made for the purposes of determining an amount payable by one Party to the hereunder, the same shall be made by

agreement between the Parties, and failing agreement by an internationally recognised firm of accountants appointed by the Parties. In the absence of agreement, each Party shall nominate an independent expert, each of whom will produce its forecast or calculation. If the difference between the results of either forecasts or calculations is 10% (ten percent) or less, then the amount payable shall be based on the average of both results. Should the difference exceed 10% (ten percent), then both independent experts shall, by agreement, appoint a third independent expert who will make its own forecast or calculation, and the amount payable will be the average of this third independent expert and the independent expert closest to the third party. In the absence of agreement on the appointment of the third independent expert, that expert shall be appointed by the President of the South African Institute of Chartered Accountants.

30.5.2 Each forecast or calculation to be made by the independent expert shall be made in accordance with prevailing Best Industry Practice. For the purpose of making any such calculation or forecast, the independent expert shall not be obliged to rely on the information submitted by the Private Party prior to the Effective Date but must have reference to the actual financial experience of the Private Party during the existence of the PPP Agreement.

### **31. EXIT PROVISIONS**

31.1 The Private Party recognises and acknowledges that SANParks, on the termination of this PPP Agreement for whatever reason, requires continuity in the conducting of the Project. The Private Party therefore irrevocably undertakes, on termination of this PPP Agreement, if required:

31.1.1 to meet with SANParks at such times prior to the termination of this PPP Agreement and in such manner as SANParks shall reasonably require, to negotiate the manner in which this PPP Agreement shall be terminated and the delivery to SANParks, or its nominee, by the Private Party to ensure the continuity of conducting the Project;

31.1.2 to use its best efforts to assist SANParks to effect the orderly and uninterrupted transition of conducting the Project;

31.1.3 to assist SANParks and to provide advice to SANParks in respect of specific service management issues;

- 31.1.4 to commit available resources to effect the transition;
- 31.1.5 for the purpose of this Clause 31, to allow SANParks reasonable access to any employee/s of the Private Party who has been employed by the Private Party in respect of conducting the Project;
- 31.1.6 to allow SANParks, the nominee or a new operator, to make offers of employment to employees of the Private Party who are, as at the termination of this PPP Agreement, employed by the Private Party for the purposes of conducting the Project;
- 31.1.7 to cede and assign to SANParks all of the contracts required by SANParks, concluded between the Private Party and third parties, in connection with the Project;
- 31.1.8 to make appropriate training available to the employees and/or agents of SANParks or the new Private Party;
- 31.1.9 to agree with SANParks the reasonable costs, including, but not limited, to overhead expenses and management PPP Fees, payable to the Private Party in respect of the functions and obligations undertaken by the Private Party in terms of this Clause 31, and
- 31.1.10 in the event that the Parties shall fail to come to an agreement in respect of any of the provisions of this Clause 31, the failure of the Parties shall be deemed to be a dispute, and shall be dealt with in accordance with Clause 29.

## **32. CHANGES IN CONTROL**

From the Signature Date as well as for the duration of the Project Term, the Private Party shall procure that there is no Change in Control in the Private Party (or in any company of which the Private Party is a subsidiary) without the prior written approval of SANParks, which approval shall not be unreasonably withheld, provided that no Change in Control may breach the provisions of SCHEDULE 5 – BEE OBLIGATIONS in any way.

## **33. CESSION, TRANSFER AND SUBSTITUTED ENTITY**

### **33.1 Transfer by the Private Party**

The Private Party may not without the prior written consent of SANParks, sub-let,

franchise, cede, assign or transfer:

33.1.1 this PPP Agreement or any Associated Agreement; or

33.1.2 any of its rights, interests or obligations thereunder;

save, in each case, to the extent required for the financing of the operation of the Skukuza Airport as envisaged in the Loan Agreements, and in terms of the provisions of Clause 33.2.

33.2 Subject to the provisions of Clause 33.1, the Private Party may either sub-let, franchise, cede, assign or transfer the operation of the whole or a part of the Skukuza Airport, provided that:

33.2.1 the period of the sub-lease, franchise, cession, assignment or transfer shall not exceed the unexpired portion of the Project Term;

33.2.2 the Private Party shall continue to be liable for the payment to SANParks of all amounts due and payable in terms of the PPP Agreement and the fact that the Private Party enters into such an agreement shall not absolve the Private Party from any liability, existing or future, of the Private Party in terms hereof;

33.2.3 the sub-lessee, cessionary, transferee, assignee or franchisee shall be bound by all the same terms and conditions as set out in this PPP Agreement as if originally a party hereto.

33.3 In the event of a breach, default or transgression of the provisions of this PPP Agreement or applicable Laws and regulations by any sub-lessee, cessionary, assignee, transferee or franchisee of the Private Party, SANParks shall be entitled to take the necessary action and directly intervene in the operations of the Skukuza Airport in order to rectify such breach, default or transgression provided that SANParks has given 30 days prior written notification to the Private Party and such sub-lessee or franchisee of the breach, default or transgression and its intention to take the necessary action and directly intervene in the operations of the Skukuza Airport.

33.4 **Substitute Entity**

33.4.1 Upon the occurrence of an event in Clause 24 entitling SANParks to terminate this PPP Agreement, and upon the expiry of the Remedy Period (in the event a Remedy Period is provided), or, where no Remedy Period is provided, upon the occurrence of

such event, SANParks shall have the right to appoint a Substitute Entity, subject to agreement by the Lenders, that the Substitute Entity nominated by SANParks-

- 33.4.1.1 is legally and validly constituted and has the capability to enter into such agreements as may be reasonably required to give effect to the substitution;
- 33.4.1.2 has the financial and technical capability sufficient to perform and assume the obligations of the Private Party under the PPP Agreement and the Loan Agreements; and
- 33.4.1.3 has the financial capability to pay any damages or other sums outstanding which SANParks is entitled to receive from the Private Party before or at the time of such substitution.

33.4.2 In the event of SANParks appointing a Substitute Entity pursuant to this Clause 33.4, the provisions of Clause 18.7, shall apply, *mutatis mutandis*.

33.4.3 The Private Party shall reimburse SANParks with all costs incurred by SANParks in exercising any of its rights in terms of this Clause 33.4 (including, without limitation, any relevant increased administrative expenses).

33.4.4 The rights of SANParks under this Clause are in addition (and without prejudice) to any other right which SANParks may have in law to claim the amount of loss or damages suffered by SANParks on account of the acts or omissions of the Private Party.

### 33.5 **Disposal of Shares**

33.5.1 SANParks will, notwithstanding the provisions of Clause 33, approve any sale of shares or other beneficial interest in the Private Party and permit that the Shareholders or beneficiaries sell any such shares or beneficial interest where such change does not bring about a change in control as understood in terms of the Companies Act 1973 (Act No. 61 of 1973) and provided that:

- 33.5.1.1 the Private Party informs SANParks of its intention to sell or permit the sale of such shares or beneficial interest at least 30 (thirty) Business Days before such sale is scheduled to take place;
- 33.5.1.2 the sale of such shares or beneficial interest does not alter the financial and technical capability of the Private Party to perform and assume the

obligations of the Private Party in terms hereof.

33.5.2 SANParks shall only have the right to refuse such sale of shares or beneficial interest if either of the two criteria above are not met, or if the proposed buyer has been convicted or otherwise fined in a court of law, or other Relevant Authority, for breaches of trading or environmental regulations in the Republic of South Africa or elsewhere.

#### **34. INTELLECTUAL PROPERTY**

34.1 It is specifically recorded that all intellectual property rights whatsoever, whether capable of registration or not, regarding SANParks' trademarks, names, logo, image and all other intellectual property matters relating to SANParks, its name, logo and/or image shall remain the sole property of SANParks.

34.2 Subject to existing rights and obligations, SANParks shall, on application by the Private Party, grant a non-exclusive right and licence to the Private Party to use SANParks' trademarks which relate to the Protected Area. Should any of SANParks' trademarks, names, logos, images and all other intellectual property matters be required for use outside of this PPP Agreement, they will be subject to terms and conditions negotiated with SANParks. This includes the granting of licences to trade merchandise with SANParks' trademarks, names, logos, images and all other intellectual property matters outside of SANParks' retail facilities.

34.3 In order to establish and maintain high standards of style, quality and proprietary associated with the Park, in the event the Private Party desires to use SANParks' trademarks or logos which relate to the Park in any way, the Private Party shall first submit the concept or a sample of the proposed use to SANParks for approval. Under no circumstances shall any use of SANParks' trademarks or logos, which relate to the Park, or the image or likeness of any trademark, logo or image, which SANParks in good faith believes reflects unfavourably upon or disparages the Park, be approved. SANParks shall use its best efforts to advise the Private Party of its approval or disapproval of the concept or sample within 15 (fifteen) Business Days of its receipt of the concept or sample. If SANParks approves the concept or sample, the Private Party shall not depart there from in any material respect without SANParks' further written approval.

34.4 If at any time SANParks withdraws its approval for the specified use of any trademark or logo, the Private Party shall forthwith discontinue all use of

SANParks' trademark or logo and shall remove from public sale or distribution, any previously approved product in respect of which SANParks has rescinded approval.

- 34.5 SANParks may withdraw approval immediately upon 5 (five) Business Days written notice to the Private Party if the Private Party or any of its officers, directors or employees commits any act or engages in any conduct which constitutes a crime, is contrary to any Regulatory Provision or offends against public morals and decency and in SANParks' reasonable opinion, materially prejudices the reputation and public goodwill of SANParks. The Private Party acknowledges that the name of the Protected Area (the "**Protected Name**") is associated with and peculiar to the Protected Area and is the intellectual property of SANParks. Consequently, the Private Party agrees that the sole and exclusive ownership of the Protected Name shall vest in SANParks and should the Private Party utilise the Protected Name, it does so only in terms of this PPP Agreement and with the prior written approval of SANParks.
- 34.6 In circumstances where the Private Party utilises any of the Protected Names, either singularly or in combination or association with any other name, it does so only in terms of this PPP Agreement and on termination of this PPP Agreement, the Private Party shall not be entitled to operate or conduct any business using the Protected Name in combination or association with any other name.
- 34.7 Within 30 (thirty) Business Days after the termination of this PPP Agreement and where the Private Party has operated a company utilising the Protected Name with the permission of SANParks, the Private Party shall either:
- 34.7.1 de-register the company bearing the Protected Name; or
- 34.7.2 change the name to a name not substantially similar to the Protected Name.
- 34.8 The naming of the airport and decoration of the airport (internal and external) shall be done in consultation with SANParks and subject to SANParks' approval.
- 34.9 In circumstances where the name chosen by the Private Party and approved by SANParks is not part of SANParks' intellectual property, then the rights of SANParks contemplated in this Clause 34 shall not be applicable and the intellectual property shall be the sole property of the Private Party.



### **35. AMENDMENTS**

This PPP Agreement may not be varied or voluntarily terminated, except by an agreement in writing signed by duly authorised representatives of the Parties.

### **36. ENTIRE AGREEMENT**

36.1 Except where expressly provided otherwise in this PPP Agreement, this PPP Agreement constitutes the entire agreement between the Parties in connection with its subject matter and supersedes all prior representations, communications, negotiations and understandings concerning the subject matter of this PPP Agreement.

36.2 Each of the Parties acknowledges that:

36.2.1 it does not enter into this PPP Agreement on the basis of and does not rely, and has not relied, upon any statement or representation (whether negligent or innocent) or warranty or other provision (in any case whether oral, written, express or implied) made or agreed to by any person (whether a Party to this PPP Agreement or not) except those expressly contained in or referred to in this PPP Agreement, and the only remedy available in respect of any misrepresentation or untrue statement made to it shall be a remedy available under this PPP Agreement; and

36.2.2 this Clause shall not apply to any statement, representation or warranty made fraudulently, or to any provision of this PPP Agreement which was induced by fraud, for which the remedies available shall be all those available under the law governing this PPP Agreement.

36.3 In the event of any conflict between this PPP Agreement and any document, contract or agreement in respect of the Project, the provisions of this PPP Agreement will prevail.

### **37. VARIATION, CANCELLATION AND WAIVER**

37.1 No provision of this PPP Agreement (including, without limitation, the provisions of this Clause) may be amended, substituted or otherwise varied, and no provision may be added to or incorporated in this PPP Agreement, except (in any such case) by an agreement in writing signed by the duly authorised representatives of the

Parties.

- 37.2 Any relaxation or delay (together “**Relaxation**”) by either Party in exercising, or any failure by either Party to exercise, any right under this PPP Agreement shall not be construed as a waiver of that right and shall not affect the ability of that Party subsequently to exercise that right or to pursue any remedy, nor shall any Relaxation constitute a waiver of any other right (whether against that Party or any other person).
- 37.3 The waiver of any right under this PPP Agreement shall be binding on the waiving Party only to the extent that the waiver has been reduced to writing and signed by the duly authorised representative(s) of the waiving Party.
- 37.4 The expiry or termination of this PPP Agreement shall not prejudice the rights of any Party in respect of any antecedent breach or non-performance of or in terms of this PPP Agreement

#### **38. LIMITATIONS ON PRIVATE PARTY ENCUMBRANCES**

The Private Party may not cede, assign, pledge, hypothecate or otherwise encumber its assets and rights in and to this PPP Agreement, either in whole or in part, without prior written consent of SANParks, which consent shall not be unreasonably withheld. The Private Party may not cede, assign, pledge, hypothecate or otherwise encumber the rights and assets of SANParks.

#### **39. GOVERNING LAW AND JURISDICTION**

- 39.1 This PPP Agreement is to be governed by and construed in accordance with the laws of the Republic of South Africa.
- 39.2 The parties submit to the jurisdiction of the Transvaal Provincial Division of the High Court to hear and decide any application, action, suit, proceeding or dispute in connection with the Project and this PPP Agreement.

#### **40. STIPULATIONS FOR THE BENEFIT OF THE LENDERS**

The Parties agree that the provisions of this PPP Agreement that refer to the Lenders comprise stipulations for the benefit of the Lenders and the Lenders may at any time by

written notice accept such stipulations in their favour provided that they accept the obligations imposed upon them in terms of this PPP Agreement and provides the Parties with their address for notices. Upon receipt of acceptance by the Lenders of the rights and obligations imposed upon them in this PPP Agreement, the Lenders shall be bound by the provisions of this PPP Agreement that relate to them. The Lenders' consent shall be required in respect of any variation or amendment to any provision of this PPP Agreement that directly confers rights and/or imposes obligations on the Lenders or that reduces the Project Term and such consent may not to be unreasonably withheld.

#### 41. NOTICES

41.1 Any notice or correspondence to be given under this PPP Agreement shall be in writing, in English, unless otherwise agreed and shall be delivered personally or sent by fax followed by the original delivered by hand.

41.2 The addresses for Notices are as follows:

**SANParks:**

Marked for the attention of:

The Chief Executive of SANParks:

c/o Legal Services

Groenkloof National Park

643 Leyds Street

Muckleneuk

Pretoria

Telephone: (012) 426-5000

Facsimile: (012) 343-3849

**<Private Party / SPV Name>**

<Address>

Marked for the attention of the Directors:

XXX

Telephone: (999) 999 9999

Facsimile: (999) 999 9999

- 41.3 A notice sent by one Party to another Party shall be deemed to be received:
  - 41.3.1 on the same day, if delivered by hand;
  - 41.3.2 on the same day of transmission if sent by telex or telefax and if sent by telefax with receipt confirming completion of transmission.
- 41.4 Either Party may change its nominated address to another address in the Republic of South Africa by prior written notice to the other Party.

SIGNED AT ..... ON THE ..... 2008.

For and on behalf of

**SOUTH AFRICAN NATIONAL PARKS**

---

who warrants his authority hereto

SIGNED AT ..... ON THE ..... 2008.

For and on behalf of

**<Private Party / SPV>**

---

who warrants his authority hereto

## 42. SCHEDULE 1 - DESCRIPTION OF THE SKUKUZA AIRPORT FACILITIES

The Skukuza Airport Facility will include all the facilities and infrastructure within the designated 'exclusive use' area in respect of each of the Buildings shown on the attached site maps attached as SCHEDULE 2 – SITE DRAWINGS OF SKUKUZA AIRPORT.

### 42.1 Skukuza Airport

The Skukuza Airport that will be managed by the Private Party will include the airport as demarcated by the airport fence but will exclude certain buildings as outlined in this section:

#### 42.1.1 Existing fenced area including:

42.1.1.1 Main airport building and demarcated arrival & departure areas outside the main building but excluding the center circular area that will be used by SANParks and or the rental company as well as the specific area earmarked for the shop / tea garden

42.1.1.2 Runway area with maintenance to the runway and adjacent areas to be performed by SANParks

42.1.1.3 Bunker area to form part of the runway area. However, in some instances SANParks may decide to use this area for functions (SANParks and the Private Party to compile a procedure manual with regards to the use of this facility).

#### 42.1.2 Area / buildings excluded:

42.1.2.1 NDB Beacon (Private Party to ensure that the NDB Beacon is functional)

42.1.2.2 Weather Station situated on the right when turning towards the airport from the main Skukuza Tshokwane road

42.1.2.3 Hangers and fuel drum storage area

42.1.2.4 ECI Offices to the east of the parking area

42.1.2.5 The parking area

42.1.2.6 Underground fuel storage facilities which is to be managed by the Fuel

Service Provider

43. SCHEDULE 2 – SITE DRAWINGS OF SKUKUZA AIRPORT

43.1 Airport Building:

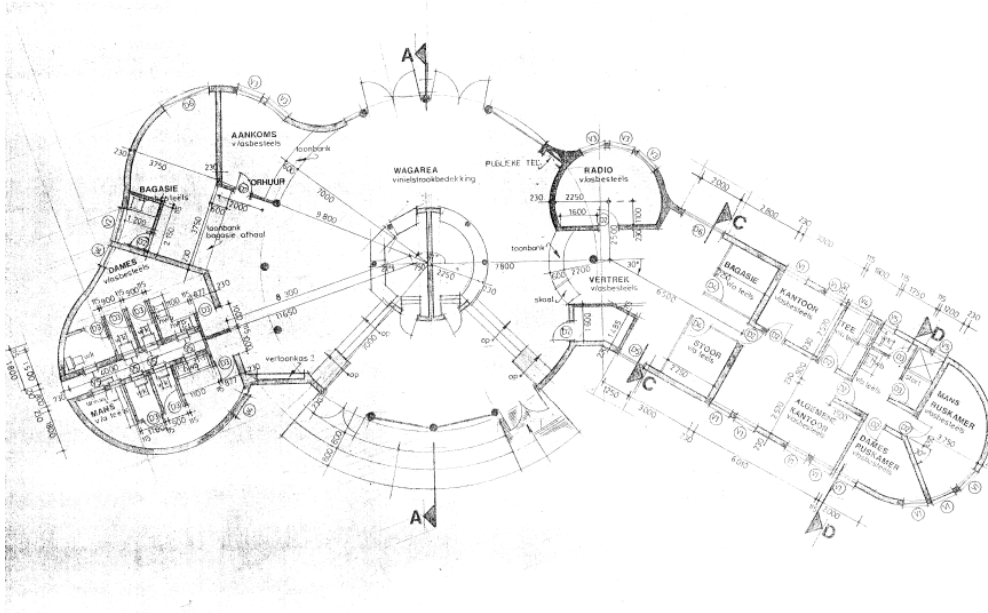

43.2 Other Airport Buildings

Airport Luggage Kiosk:

Frontal view:

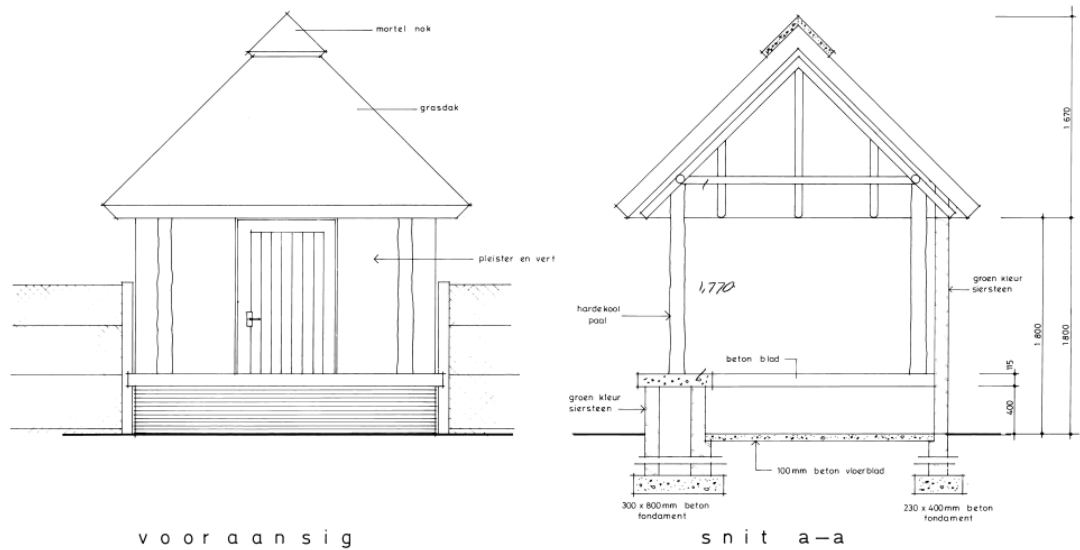

Top view:

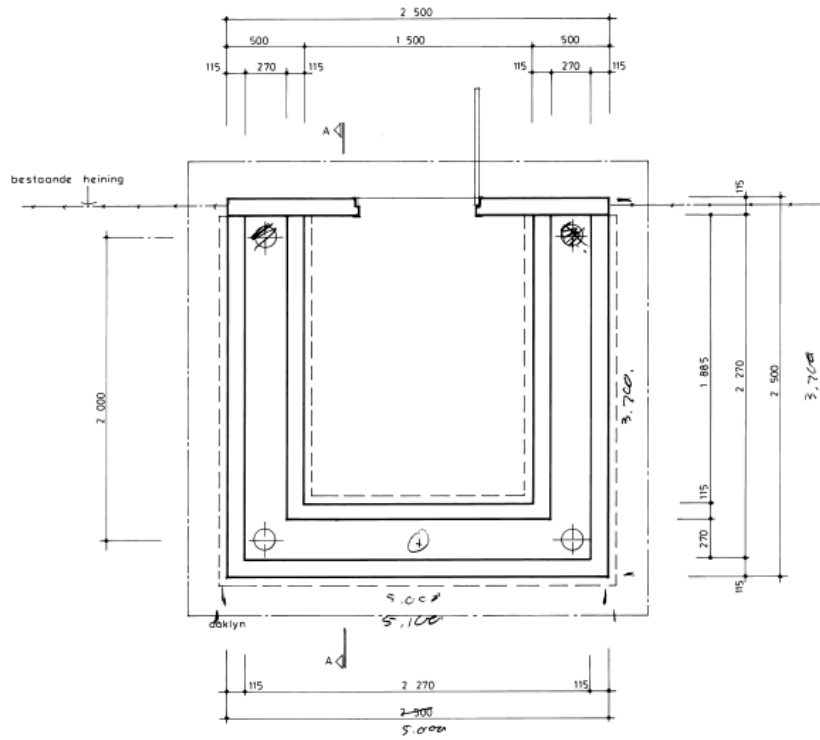

P L A N

### 43.3 Runway cross section

The Skukuza Airport runway is 1500 metres long.

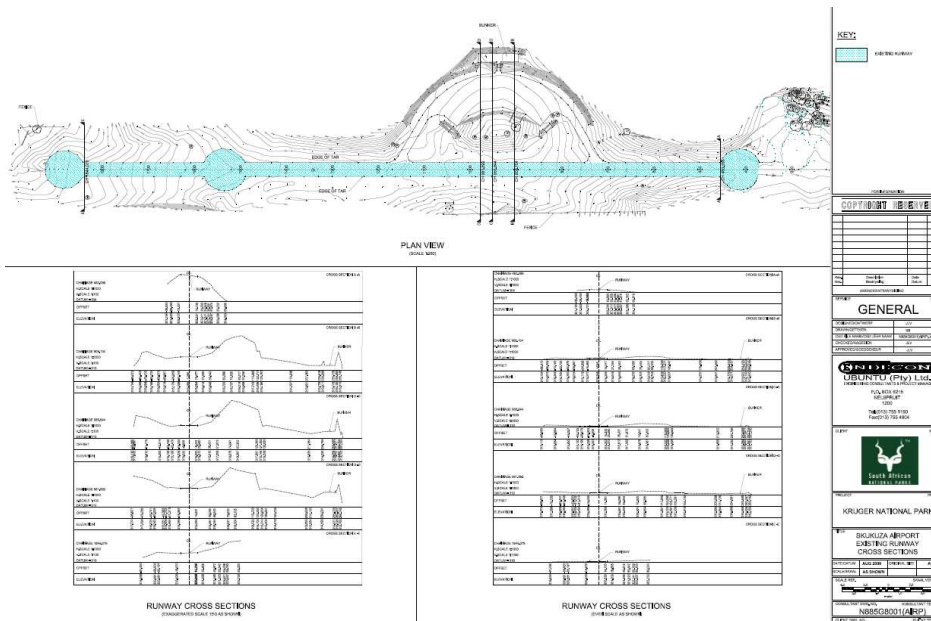



#### 44. SCHEDULE 3 – PRIVATE PARTY OPERATIONAL REQUIREMENTS

##### 44.1 Flights and flight tracks

44.1.1 The Private Party is solely responsible to manage and operate the Skukuza Airport.

This management and operation applies to the following:

44.1.1.1 Scheduled flights;

44.1.1.2 Chartered flights; and

44.1.1.3 SANParks Management Aircrafts.

44.1.2 The Private Party is obliged to ensure that valid agreements are negotiated with a carrier that will fly scheduled flights into Skukuza Airport.

44.1.3 The scheduled flights should comply with the following:

44.1.3.1 Total number of seats available through the scheduled flights should not be less than 1260 per week;

44.1.3.2 Total noise pollution:

44.1.3.2.1 Grand total (DB) over receptive points;

44.1.3.2.2 Grand total (DB) of surface area affected

44.1.3.3 Total visual pollution: A maximum of 21 scheduled flights per week with a maximum of 5 scheduled flights per day will be allowed:

44.1.3.4 Total omissions allowed: As per bid submission

44.1.4 Flight paths to be enforced (as per the recommendations outlined in the “EMP and specialist studies for the Commercialisation of the Skukuza Airport”).

##### 44.2 Conduct of business

44.2.1 Administration of the re-classification process (Category 2 airport to a category 4 or 5 airport, in accordance with the Bid Submission)

44.2.2 Civil Aviation Authority Regulations

#### 44.2.3 Licences

44.2.4 In the conduct of the Airport business the Private Party shall at all times maintain the Skukuza Airport and all services provided therein to the highest standard and ensure that the premises are at all times clean and safe for customers, including public access areas and public toilets at the Skukuza Airport.

#### 44.3 **Branding**

44.3.1 The Private Party must propose a design theme that is in keeping with the overall “Bush” ambience and atmosphere. Hence, the appearance, signage and internal décor of the Skukuza Airport and uniforms of the Skukuza Airport personnel must be distinct from brands that are offered outside of the Protected Area by private operators.

44.3.2 The Private Party will be permitted to establish an indigenous African theme for the Skukuza Airport, incorporating a contemporary touch, natural and cultural elements and creating an enticing and vibrant ambience.

44.3.3 Notwithstanding the provisions of Clause 34, SANParks’ logo may be featured at the Skukuza Airport, subject to SANParks’ conditions and approval. SANParks will have control over the use of its image.

#### 44.4 **Service Provision / Operating hours**

##### 44.4.1 Flights landing hours

44.4.1.1 Scheduled flights: 10h30 to 13h30

44.4.1.2 Chartered flights: 09h00 to 15h00

#### 44.5 **Facilities and services**

44.5.1 As per CAA regulations for specific Category Airport.

44.5.2 Safety and security services.

44.5.3 Screening of passengers.

44.5.4 Ground handling

44.5.5 Check-in procedures

44.5.6 Tagging of luggage

44.5.7 The Design Plan submitted by the Private Party must be adhered to unless otherwise agreed by SANParks.

44.5.8 The Private Party is obliged to provide universal access at the Skukuza Airport.

**44.6 Uniforms**

44.6.1 The Private Party is obliged to provide all staff with suitable and customised apparel in line with the theme proposed for the Skukuza Airport.

44.6.2 All apparel must be relevant to the specific function performed by staff members and comply with Legislation and Health and Safety Standards.

44.6.3 The Private Party will be obliged to introduce and provide all staff with the applicable uniform on or before Operation Commencement Date.

**44.7 Benchmark Pricing and Control**

44.7.1 SANParks will expect the Private Party to negotiate the seat prices with the scheduled flight carrier/s in order to make the route viable and attractive.

44.7.2 Seats for SANParks personnel: Three (3) confirmed seats per flight should be available for use by SANParks at 10% of the rate. SANParks employees and their families will be allowed seats at 10% of the rate on a last minute booking basis (details to be agreed).

44.7.3 The private Party is obliged to charge market-related prices with regards to landing charges, parking charges and passenger service charges and failure to do so will be dealt with in accordance with the provisions of Clause 24.1.5 and 24.2.1.2.

**44.8 Skukuza Airport Staff and Staff Transport**

In the conduct of the Skukuza Airport business the Private Party shall be solely responsible for all staffing requirements at the Skukuza Airport. The Private Party is responsible for the transport of their employees from the workplace (Skukuza Airport) to the living quarters. The Private Party is responsible for the transport of their staff to the required medical facilities. In the event that SANParks' transport can be utilised, the related cost of transport will be for the Private Party's account.

**44.9 Staff Housing**

The Private Party will be obliged to conclude separate Housing Rental Agreements with SANParks for the employees that will reside in SANParks' housing. The housing availability and rentals are detailed in SCHEDULE 14 – EMPLOYEE HOUSING AND RENTALS; however, the rental rates are subject to revision from time to time. The Private Party will be directly accountable to settle all housing rentals with SANParks within 7 (seven) days following the end of each calendar month. SANParks will not be accountable for the recovery thereof from individual employees of the Private Party.

#### 44.10 **Utility Charges**

The Private Party is responsible for all utility charges i.e. electricity, water, waste and refuse removal and sewerage. SANParks will charge the utilities to the Private Party on a monthly basis and the Private Party is obliged to settle such accounts within 7 (seven) days. The water and electricity usage will be metered and cost be determined as per the tariff document that is published yearly (or any other revision) by SANParks.

A generator which belongs to the South African Airforce will be used if and when power failures occur and will be maintained by SANParks and / or the SA Airforce.

44.10.1 Telephone accounts - In the conduct of the Skukuza Airport business the Private Party shall procure the maintenance of sufficient telephone services at the Skukuza Airport. The Private Party shall be responsible for the payment of all telephone accounts related to the Skukuza Airport.

44.10.2 Waste - The Private Party must ensure that waste disposal facilities, including rubbish or waste removal bins, are clean and free from noxious or offensive odorous, that the waste disposal facility is not unsightly and the waste is frequently removed and the area surrounding the waste disposal facility is clean, neat and tidy. The Private Party must adhere to SANParks' Waste Policies as amended from time to time. The Private Party will be responsible for the costs of all solid and liquid waste processing. It is advisable that baboon proof waste bins be used at the Skukuza Airport.

44.10.3 Water – Water meters are installed at the Skukuza Airport to monitor the water usage by the Private Party. The related cost will be for the account of the Private Party.

#### 44.11 **Meetings**

To provide for a forum where the parties can resolve disputes and agree operational issues, the Private Party may be requested to attend SANParks meetings. Agreement on this can be reached and can vary depending on cooperation between the parties.

#### 44.12 **Procedure Manuals**

44.12.1 The Private Party is obliged to comply with the Private Party's AOM submitted with the Private Party's Bid Submission. Any deviation by the Private Party from this AOM is subject the approval of SANParks.

44.12.2 The Private Party is obliged to adhere to SANParks' Concession Procedure Manual as amended from time to time. Even though not customised for the management of an airport, the Concession Procedure Manual will define the roles, responsibilities and procedures with regard to housing, transport of staff, maintenance, infrastructural upgrades and expansions etc. These procedure manual needs to be work shopped and agreed as a working document between the parties and be used as a tool to ensure optimal customer service.

44.12.3 The Private Party is obliged to comply with the OEMG. Any deviation by the Private Party from this OEMG is subject the approval of SANParks.

44.12.4 The Private Party is obliged to, together with SANParks compile a SANParks Management Airport Operating Manual (SMAOM) which would outline the rules for the SANParks aircrafts used for management purposes.

#### 44.13 **Quality Audit**

The Private Party shall participate in and work together with SANParks in conducting and establishing quality audits.

#### 44.14 **Institutional Policies and Objectives**

The Private Party is obliged to comply with and adhere to SANParks' Policies and Initiatives as amended from time to time i.e. HIV Aids Policy, Health and Safety Forums etc.

#### 44.15 **Games**

The Private Party shall not be entitled to introduce any arcade type amusement or

gaming machines at the Skukuza Airport without the prior written approval of SANParks.

44.16 **Publications**

The Private Party may not display, offer for sale or sell any offensive reading material and shall be obliged, at no cost to SANParks, to promote SANParks' publications, magazines or other publication material.

**45. SCHEDULE 4 – PRIVATE PARTY BID SUBMISSION**

The Private Party shall adhere to and comply with the Private Party's Bid Submission. Notwithstanding the generality of the a foregoing, the Private Party is obliged to adhere to the Design Plan, Business and Operational Plan and Environmental Plan attached herewith.

## 46. SCHEDULE 5 – BEE OBLIGATIONS

In this Schedule,

- 46.1 any term, defined in the Broad-based Black Economic Empowerment Act, No. 53 of 2003 ("**BEE Act**"), or in terms of any Codes of Good Practice issued in terms of section 9 of the BEE Act, when used in the scorecard below shall have the same meaning as there defined, save where such meaning may be in conflict with the provisions of the Tourism BEE Charter and Scorecard, in which case the provisions of the Tourism BEE Charter and Scorecard will prevail.
- 46.2 The following terms, as used herein, shall have the following meanings:
- 46.2.1 "**Black Empowered SMME**" means a small, medium or micro enterprise (with a turnover of up to R10 million per annum) which has between 25 percent and 50 per cent direct ownership and management by Black People;
- 46.2.2 "**Black Owned SMME**" means a small, medium or micro enterprise (with a turnover of up to R10 million per annum) which has more than 50 per cent direct ownership and management by black people;
- 46.2.3 "**Black People**" is as defined in the BEE Act, save that it is limited to South African citizens. In other words, Black People are Africans, Coloureds and Indians who are South African citizens. For avoidance of doubt, this term does not include juristic persons or any form of enterprise other than a sole proprietor. "**Black Person**" means any such citizen;
- 46.2.4 "**Black Women**" means female Black People;
- 46.2.5 "**Board Representation**" refers to membership by Black People of the duly constituted board of directors (or equivalent structure) of an enterprise and is calculated upon the basis of the percentage that black directors hold to the total number of directors of that enterprise;
- 46.2.6 "**Community Trust**" means a trust registered in terms of the Trust Property Control Act;
- 46.2.7 "**Community Trust Ownership**" means Equity in the Private Party which must, as a mandatory provision of the Project, be acquired by a Community Trust;



46.2.8 "**Direct Ownership**" means ownership of an equity interest in an enterprise where such equity interest comprises:

- 46.2.8.1 the right to participate in the voting rights in that enterprise;
- 46.2.8.2 the right to receive unencumbered economic interest (such as dividends) flowing to the shareholders of that enterprise; and
- 46.2.8.3 Broad-based BEE schemes, employee share option schemes (ESOPs) and other employee share schemes, where the beneficiaries have the unconditional right to receive economic benefits and the capacity to elect and remove trustees, are specifically recognised as direct ownership. The flow-through principle will be applied to determine the level of black ownership represented by the employee share option scheme;
- 46.2.8.4 Direct ownership is measured as being the lower of the level of black participation in voting rights and black participation in the unencumbered economic interest of an enterprise, measured using the flow-through principle;

46.2.9 "**Discretionary Procurement**" includes all amounts expended by an enterprise subject to measurement. Discretionary procurement excludes:

- 46.2.9.1 employment related expenditure;
  - 46.2.9.2 procurement from public utilities and natural monopolies; and
  - 46.2.9.3 facilitated procurement by travel agencies or other travel distribution providers where the choice of service providers remains with the consumer;
- 46.2.10 "**Employees with no prior working experience**" refers to those employees who have no formal employment experience prior to joining an enterprise in tourism. Formal employment does not include learner ships, traineeships or short-term and temporary assignments;

46.2.11 "**Enterprise Development**" may take a variety of forms, including:

- 46.2.11.1 direct investment in Black Owned and Black Empowered SMMEs;
- 46.2.11.2 joint ventures with Black Owned and Black Empowered SMMEs that

- result in "substantive" skills transfer;
- 46.2.11.3 support and funding for the grading of emerging tourism companies, as well as providing mentorship, business relationships and linkages which, in turn, provide business opportunities to these enterprises; and
- 46.2.11.4 twinning initiatives with Black Owned and Black Empowered SMMEs which result in cost savings or revenue generation for those SMMEs;
- 46.2.12 "**Executive Representation**" refers to the participation by Black People in the senior non-board level management of an enterprise and more specifically, targets management levels which influence the strategic and operational management of an enterprise. Participation is measured upon the basis of the percentage that black executive managers hold to the total number of executive managers of that enterprise;
- 46.2.13 "**Learner ship**" refers to learner ships as defined in the Skills Development Act, No. 97 of 1998, amended in 2003;
- 46.2.14 "**Local**" means the geographic area specified by SANParks in the Request for Proposals issued by SANParks in respect of the Project, being either within 50 km kilometre radius of the Picnic Facility or the tribal authorities within such radius attached as SCHEDULE 16 - TRIBAL AUTHORITIES NEIGHBOURING THE KNP;
- 46.2.15 "**Management**" refers to all senior and middle management who do not form part of the executive management of the board of directors of the Private Party;
- 46.2.16 "**Ownership**" refers to equity participation and the ability to exercise rights and obligations, including voting rights and the rights to the flow of economic benefits, which accrue under such ownership;
- 46.2.17 "**Preferential Procurement**" refers to all spend with BEE compliant suppliers, to be calculated as follows:
- 46.2.17.1 one Rand (R1) for every one Rand (R1) spent with Excellent BEE Contributors, Good BEE Contributors, BEE Compliant SMMEs and Black Women Owned BEE Contributors; and
- 46.2.17.2 fifty cents (50c) for every one Rand (R1) spent with Satisfactory BEE

Contributors; all of which terms are defined as follows:

- 46.2.17.3 an Excellent BEE Contributor means a company which has scored in excess of 90 percent on a BEE scorecard under a scorecard governing that company's sector or a BEE scorecard issued in the Codes of Good Practice and under the BEE Act;
- 46.2.17.4 a Good BEE Contributor means a company which has scored in excess of 65 percent, but less than 90 percent, on a BEE scorecard under a scorecard governing that company's sector or a BEE scorecard issued in the Codes of Good Practice and under the BEE Act;
- 46.2.17.5 a Satisfactory BEE Contributor means a company which has scored in excess of 40 percent but less than 65 percent, on a BEE scorecard under a scorecard governing that company's sector or a BEE scorecard issued in the Codes of Good Practice and under the BEE Act;
- 46.2.17.6 a Limited BEE Contributor means a company which has scored less than 40 percent, on a BEE scorecard under a scorecard governing that company's sector or a BEE scorecard issued in the Codes of Good Practice and under the BEE Act;
- 46.2.17.7 a BEE Compliant SMME means a small, medium or micro enterprise (with a turnover of up to R10 million per annum) which is either an Excellent, Good or Satisfactory Contributor to BEE; and
- 46.2.17.8 a Black Women Owned BEE Contributor is a company which is more than 30 percent owned by black women and which is also an Excellent, Good or Satisfactory contributor to BEE;
- 46.2.18 **"Skills Development Spend"** refers to investment in skills development initiatives through both external training providers and the quantifiable costs of accredited internal training programmes. Internal training spend does not include the opportunity cost of employees attending the skills development initiatives;
- 46.2.19 **"Supervisory"** refers to the junior management and professional staff;
- 46.2.20 **"TOMSA (Tourism Marketing South Africa) Levy Collectors"** refers to tourism enterprises who are registered to raise funds on behalf of the trust;
- 46.2.21 **"Total Employee Time"** refers to the total working hours calculated as the

product of the total number of employees and their standard working hours;

46.2.22 **"Total Staff"** refers to all employees and/or contractors, excluding those accounted for under Strategic Representation, from whom the tourism enterprise is responsible for the collection and payment of applicable employee tax. The intention of the scorecard below is to include temporary staff in the definition of total staff, since tourism is an industry that relies heavily on temporary, casual and seasonal staff.

46.3 **2009 Milestones and Weightings**

46.3.1 The Private Party shall from Operation Commencement Date to 31 December 2009 (**"First Period"**) comply with the commitments and undertakings set out in the following table.

| Indicator                       | 2009 Weightings |               | 2009 MILESTONES   |                |
|---------------------------------|-----------------|---------------|---|----------------|
|                                 | Weighting       | Sub-weighting | Indicators to measure BEE achievement   | 2009 Milestone |
|                                 |                 |               |   | Target         |
|                                 |                 |               |   | C              |
| A                               | B               |               |   |                |
| <b>Ownership</b>                | 15%             | 10%           | Percentage share of economic benefits as reflected by direct shareholding by black people | 14%            |
|                                 |                 | 5%            | Community trust ownership   | 7%             |
| <b>Strategic representation</b> | 14%             | 3.0%          | Black people as a percentage of board of directors  | 30%            |
|                                 |                 | 3.0%          | Black women as a percentage of board of directors   | 15%            |
|                                 |                 | 2.0%          | Local people as a percentage of board of directors  | 15%            |
|                                 |                 | 3.0%          | Black people as a percentage of executive management                                      | 30%            |
|                                 |                 | 3.0%          | Black women as a percentage of executive management                                       | 15%            |
| <b>Employment equity</b>        | 14%             | 1.5%          | Black people as a percentage of management  | 35%            |
|                                 |                 | 1.5%          | Black women as a percentage of management   | 18%            |
|                                 |                 | 1.5%          | Local people as a percentage of management  | 15%            |
|                                 |                 | 1.5%          | Black people as a percentage of supervisors, junior and skilled employees                 | 45%            |

| Indicator                       | 2009 Weightings |               | 2009 MILESTONES   |                |
|---------------------------------|-----------------|---------------|---|----------------|
|                                 | Weighting       | Sub-weighting | Indicators to measure BEE achievement   | 2009 Milestone |
|                                 |                 |               |   | Target         |
|                                 |                 |               |   | C              |
| A                               | B               |               |   |                |
|                                 |                 | 1.5%          | Black women as a percentage of supervisors, junior and skilled employees  | 23%            |
|                                 |                 | 1.5%          | Local people as a percentage of supervisors, junior and skilled employees   | 35%            |
|                                 |                 | 1.5%          | Black people as a percentage of total staff   | 53%            |
|                                 |                 | 1.5%          | Black women as a percentage of total staff  | 28%            |
|                                 |                 | 2%            | Local people as a percentage of total staff   | 50%            |
| <b>Skills development</b>       | 20%             | 5%            | Percentage of payroll spend on skills development (including skills development levy) on all accredited training  | 3%             |
|                                 |                 | 5%            | Percentage of skills development spend on all black employees   | 75%            |
|                                 |                 | 5%            | Number of learner ships as a percentage of total employees  | 2%             |
|                                 |                 | 5%            | Number of black learners as a percentage of total learners  | 80%            |
| <b>Preferential procurement</b> | 15%             | 10%           | Spend on BEE compliant companies as a percentage of total procurement spend   | 40%            |
|                                 |                 | 5%            | Spend on local BEE compliant companies as a percentage of total procurement spend   | 20%            |
| <b>Enterprise development</b>   | 14%             | 7%            | The sum of percentage spend of post-tax profits on enterprise development and percentage employee time contributed to enterprise development over total management time | 1%             |
|                                 |                 | 7%            | Enhanced revenue and/or cost savings and/or twining initiatives facilitated for black owned SMMEs, as a percentage of revenue.  | 1%             |

| Indicator                                       | 2009 Weightings |               | 2009 MILESTONES  |                |
|---|-----------------|---------------|--|----------------|
|   | Weighting       | Sub-weighting | Indicators to measure BEE achievement  | 2009 Milestone |
|   |                 |               |  | Target         |
|   |                 |               |  | C              |
| A   | B               |               |  |                |
| <b>Social development and industry specific</b> | 8%              | 3%            | Percentage CSI spend of post-tax profits on education, community programmes, job creation, training, health, conservation, community tourism and marketing activities to develop local black tourist market (or percentage management time over total employee time) | 1%             |
|   |                 | 2%            | Percentage of new recruits with no prior work experience   | 10%            |
|   |                 | 3%            | Status of TOMSA levy collector   | Yes            |
| <b>Total BEE points</b>                         | <b>100</b>      | <b>100</b>    |  |                |

#### 46.4 2104 Milestones and Targets

46.4.1 The Private Party shall from 1 January 2010 to 31 December 2014 (“**Second Period**”) comply with the commitments and undertakings set out in the following table.

| Indicator                       | 2014 Weightings |               | 2014 MILESTONES   |                |
|---------------------------------|-----------------|---------------|---|----------------|
|                                 | Weighting       | Sub-weighting | Indicators to measure BEE achievement   | 2014 Milestone |
|                                 |                 |               |   | Target         |
|                                 |                 |               |   | C              |
| A                               | B               |               |   |                |
| <b>Ownership</b>                | 20%             | 13%           | Percentage share of economic benefits as reflected by direct shareholding by black people | 20%            |
|                                 |                 | 7.0%          | Community trust ownership   | 10%            |
| <b>Strategic representation</b> | 12%             | 2.5%          | Black people as a percentage of board of directors  | 50%            |
|                                 |                 | 2.5%          | Black women as a percentage of board of directors   | 25%            |
|                                 |                 | 2.0%          | Local people as a percentage of board of directors  | 25%            |

| Indicator                       | 2014 Weightings |               | 2014 MILESTONES  |                |
|---------------------------------|-----------------|---------------|--|----------------|
|                                 | Weighting       | Sub-weighting | Indicators to measure BEE achievement  | 2014 Milestone |
|                                 |                 |               |  | Target         |
|                                 |                 |               |  | C              |
| A                               | B               |               |  |                |
|                                 |                 | 2.5%          | Black people as a percentage of executive management   | 50%            |
|                                 |                 | 2.5%          | Black women as a percentage of executive management  | 25%            |
| <b>Employment equity</b>        | 12%             | 1.0%          | Black people as a percentage of management   | 50%            |
|                                 |                 | 1.0%          | Black women as a percentage of management  | 25%            |
|                                 |                 | 2.0%          | Local people as a percentage of management   | 25%            |
|                                 |                 | 1.0%          | Black people as a percentage of supervisors, junior and skilled employees  | 65%            |
|                                 |                 | 1.0%          | Black women as a percentage of supervisors, junior and skilled employees   | 35%            |
|                                 |                 | 2.0%          | Local people as a percentage of supervisors, junior and skilled employees  | 45%            |
|                                 |                 | 1.0%          | Black people as a percentage of total staff  | 75%            |
|                                 |                 | 1.0%          | Black women as a percentage of total staff   | 40%            |
|                                 |                 | 2.0%          | Local people as a percentage of total staff  | 60%            |
| <b>Skills development</b>       | 18%             | 4.5%          | Percentage of payroll spend on skills development (including skills development levy) on all accredited training | 3%             |
|                                 |                 | 4.5%          | Percentage of skills development spend on all black employees  | 75%            |
|                                 |                 | 4.5%          | Number of learner ships as a percentage of total employees   | 2%             |
|                                 |                 | 4.5%          | Number of black learners as a percentage of total learners   | 80%            |
| <b>Preferential procurement</b> | 18%             | 12.0%         | Spend on BEE compliant companies as a percentage of total procurement spend                                      | 50%            |
|                                 |                 | 6.0%          | Spend on local BEE compliant companies as a percentage of total procurement spend                                | 25%            |

| Indicator                                       | 2014 Weightings |               | 2014 MILESTONES  |                |
|---|-----------------|---------------|--|----------------|
|   | Weighting       | Sub-weighting | Indicators to measure BEE achievement  | 2014 Milestone |
|   |                 |               |  | Target         |
|   |                 |               |  | C              |
| A   | B               |               |  |                |
| <b>Enterprise development</b>                   | 10%             | 5.0%          | The sum of percentage spend of post-tax profits on enterprise development and percentage employee time contributed to enterprise development over total management time  | 1%             |
|   |                 | 5.0%          | Enhanced revenue and/or cost savings and/or twining initiatives facilitated for black owned SMMEs, as a percentage of revenue.   | 1%             |
| <b>Social development and industry specific</b> | 10%             | 6.0%          | Percentage CSI spend of post-tax profits on education, community programmes, job creation, training, health, conservation, community tourism and marketing activities to develop local black tourist market (or percentage management time over total employee time) | 1%             |
|   |                 | 1.0%          | Percentage of new recruits with no prior work experience   | 10%            |
|   |                 | 3.0%          | Status of TOMSA levy collector   | Yes            |
| <b>Total BEE points</b>                         | <b>100</b>      | <b>100</b>    |  |                |

#### 46.5 Milestones and Targets Post-2014

46.5.1 The BEE Milestones and Targets for the duration of the PPP Term and in particular for the period from 1 January 2015 to the end of the PPP Term shall be determined by the restructured editions of the Tourism Charter and Scorecard as gazetted from time to time.

46.5.2 The Tourism BEE Charter was developed by the Department of Environmental Affairs and Tourism in May 2005 and on 20 June 2008, the Broad-Based Black Economic Empowerment Act (53/2003): Codes of Good Practice on Black Economic Empowerment was Gazetted (Government Gazette No. 31168).

46.5.3 The milestones and targets of the Tourism BEE Charter and Scorecard could thus



be amended from time to time and the provisions of this SCHEDULE 5 – BEE OBLIGATIONS would be modified accordingly. The Private Party would receive notification of such amendments and be provided with a satisfactory remedy period to address the amendments.

**46.6 External BEE Verification**

46.6.1 The Private Party shall appoint a reputable external verification agency to determine the Private Party's BEE status and a copy of such an independent verification certificate shall be provided to SANParks within 30 (thirty days) after the end of each Project Year.

46.6.2 The Private Party shall be obliged in terms of this PPP Agreement to, at a minimum, be rated as a **Good BEE Contributor** by an external verification agency for each Project Year.

46.6.3 In the event of default by the Private Party to comply with the provisions of the a foregoing Clause 46.6.2 and the Private Party default is not remedied before the expiry of the period referred to in the notice by SANParks, SANParks may terminate this PPP Agreement with immediate effect by written notice to the Private Party.

**47. SCHEDULE 6 – PPP FEE**

**47.1 Variable PPP Fee**

47.1.1 The Variable PPP Fee shall be expressed as a flat percentage of Gross Revenue generated by the Skukuza Airport included under the PPP Agreement.

47.1.2 The Variable PPP Fee shall be as follows:

**VARIABLE PPP FEE = \_\_\_\_% of GROSS REVENUE**

**47.2 Minimum PPP Fee**

The following Minimum PPP Fees are expressed in April 2007 South African Rand, and will be adjusted throughout the Project Term of the PPP Agreement according to movement in the Consumer Price Index:

| PPP Opportunity | MINIMUM PPP FEE |               |
|-----------------|-----------------|---------------|
|                 | Per Annum       | Per Month     |
| Skukuza Airport | 600,000         | 50,000        |
| <b>TOTAL</b>    | <b>600,000</b>  | <b>50,000</b> |

**48. SCHEDULE 7 – SALE ASSETS**

**49. SCHEDULE 8 – EMPLOYEES**

No employees will be transferred to the new operator.

## **50. SCHEDULE 9 – ENVIRONMENTAL SPECIFICATIONS FOR THE OPERATION OF THE SKUKUZA AIRPORT WITHIN THE PROTECTED AREAS**

### **50.1 Introduction**

South African National Parks (SANParks) in 2001, embarked on an initiative to commercialise certain of its operations. One aspect of this effort is the outsourcing of the management of the Skukuza Airport. As the custodian for the Parks, however, SANParks will retain broad oversight responsibility for the operation of the outsourced facilities. In this context, SANParks has established Environmental Specifications to ensure that the operation of the Skukuza Airport be done in the most environmental friendly way. In preparation to the outsourcing of the Skukuza Airport, SANParks has contracted a specialist group to draft an EMP – refer SCHEDULE 19 – DRAFT EMP AND SPECIALIST STUDY FOR THE COMMERCIALISATION OF THE SKUKUZA AIRPORT (SIVEST). This EMP need to be practiced and modified for optimal benefit to the environment in light of the commercial opportunity within a protected area.

### **50.2 Legislative Basis for these Guidelines**

SANParks is bound by a number of statutes with relevance to environmental management of Parks, including (without limitation) the National Environmental Management: Protected Areas Act, 2003 (Act No. 57 of 2003) (NEMPAA); the National Water Act 36 of 1998; the Water Services Act, 108 of 1997; the National Environmental Management Act, 107 of 1998 (NEMA); the National Environmental Management: Air Quality Act; the Hazardous Substances Act, 15 of 1973; and the National Heritage Resources Act.

Authorization of any development in a Protected Area is governed by the NEMA and the NEMPAA, and regulations. Any changes to infrastructure or operations require written approval from SANParks and are subject to the prescribed policies and procedures.

The process for upgrading the airport building will be undertaken as per SANParks internal policies and procedures, and authorizations given by the Department of Environmental Affairs and Tourism and where relevant by SANParks.

The EIA laws and Regulations do not specifically require an EIA for a change such as the changes anticipated to happen at the Skukuza Airport where the airport will

change to a Category 4 or 5 airport as opposed to a Category 2 airport (as is currently the case). However, given that the development is taking place within a protected area such as a National Park, SANParks requires environmental scoping to be conducted on any proposal to expand or modify the existing structures that are being bid for. Modifications include both structural changes to the facility and additions to the facility or its environs, including signage. The scoping report must be submitted to SANParks who might decide that it needs to be submitted to DEAT, the "relevant environmental authority" as defined in the EIA Guideline documents.<sup>1</sup>

### 50.3 **Guidelines Based on SANParks Internal Requirements**

SANParks follows an adaptive management system. The adaptive management system is described in the KNP park management plan and includes an objectives hierarchy, management programmes and the costing programme.

In line with such adaptive management system, the KNP is in the process of developing and Operational Management Plan based on the findings of due diligence assessment and legal assessment.

Upon completion and implementation the Operational Management Plan of the Kruger National Park ("**KNP Implementation**"), the Private Party will be required to:

- 50.3.1 Undertake a due diligence legal assessment within the first year post KNP Implementation in accordance with the Protected Area legal compliance plan and standard (KNP has a legal review standard and preferred supplier). Such assessment must be repeated every 5 (five) years;
- 50.3.2 Compile an action plan to address the findings of the legal assessment with time frames approved by SANParks. This will exclude findings that relate to SANParks' responsibilities;
- 50.3.3 Address all findings to the satisfaction of SANParks within year 2 post KNP Implementation, except where prior written approval from SANParks is obtained to rectify the problem at another specified date;
- 50.3.4 Compile a risk analysis in conjunction with the KNP within year 2 post KNP

---

<sup>1</sup>In the case of the SANParks, the 'relevant environmental authority' for review of EIAs conducted in National

Implementation. KNP is in the process of developing a template for a risk analysis and it can be done internally at no additional cost based on the outcome of the legal assessment;

50.3.5 Action the required mitigation measures of the risk analysis within a specified time (e.g. 6 months);

50.3.6 Revise the risk analysis and action plan annually and submit it to SANParks for approval;

50.3.7 Ensure that the Airport Operations Manual (AOM) aligns with the park's management plan, Corporate Policies and all procedures and standards. The risk analysis is the process followed to inform the contents of the AOM;

50.3.8 Audit the AOM annually by a SANParks approved auditor and submit the audit report to SANParks for approval within 1 calendar month of the audit undertaken. SANParks reserves the right to request changes to the recommended solutions/actions proposed which must be implemented within 1 month of the request being tabled to the Private Party; and

50.3.9 Address all audit findings within a specified time of 3 months of the finding to SANParks' satisfaction.

Apart from this the Private Party will have to:

50.3.10 conduct an **environmental review** considering all environmental aspects of the Skukuza Airport activities, products and services, methods to assess these, its legal and regulatory framework and existing environmental management practices and procedures, prior to operations and thereafter every 6 months of operation;

50.3.11 in the light of the results of the review that was done prior to operations, establish an effective **Environmental Management System** (EMS) to be accredited to the world's best practice standard (this being ISO 14001 or other suitable EMS). This must be aimed at achieving SANParks' environmental policy and values as defined. The management system needs to set responsibilities, objectives, means, operational procedures, training needs, monitoring and communication systems.

50.3.12 carry out an **environmental audit** assessing in particular the management system in place and conformity with the SANParks policy and Skukuza Airport's

---

programme as well as compliance with relevant environmental regulatory requirements, and adaptive management options to improve the environmental management.

50.3.13 provide a **statement** of its environmental performance which lays down the results achieved against the environmental objectives and the future steps to be undertaken in order to continuously improve its environmental performance.”

#### 50.4 **Code of Conduct**

The KNP Code of Conduct provides comprehensive rules and regulations applicable to KNP and the Private Parties alike. The Code of Conduct is considered to be internal rules and regulations in terms of the NEMPAA and is legally binding. All staff and personnel associated with the Private Party is obliged to comply to the requirements of the Code of Conduct at all times.

#### 50.5 **Environmental Specifications**

SANParks anticipates that national Legislation together with the Operational Environmental Management Guideline (OEMG) will adequately cover many of the environmental issues that will arise. Private Parties will be expected to comply at all times with the provisions of the Environmental Specifications as amended from time to time.

##### 50.5.1 **Visual Impacts**

50.5.1.1 Any development within the Protected Area must take due cognisance of the visual impacts it may have on surrounding areas and other Park users. SANParks has based its Specifications for visual impacts on interpretations of existing management documents. It is assumed that ‘visible’ means to the naked eye. All changes (including lighting) at the airport should be considered in terms of visual impacts that will result.

50.5.1.2 The building style - structure, materials and design as well as internal decoration -- must be in harmony with the environment.

##### 50.5.2 **Building Materials**

The use of building materials sourced inside the Protected Area will not be permitted as a general rule. In exceptional circumstances, it may be appropriate to use such materials. In those instances, the Private Party must



obtain written approval from SANParks.

### **50.5.3 Lighting**

Developments that blend into the landscape during daylight hours may nonetheless be visible over long distances at night as a result of artificial lighting. The Private Party shall therefore take the impacts of lighting into consideration in any modifications to existing structures, as well as in its operation of the facility. Lights illuminating pathways and other areas must be low to the ground and directed downwards.

### **50.5.4 Lightning Arrestors and Radio Masts**

50.5.4.1 If the Private Party proposes to erect new structures, these must be (where possible) included in the Bid Submission. Construction of radio masts is a prescribed activity under South Africa's EIA Regulations.

50.5.4.2 SANParks is well aware that standards and "best practices" with regard to telecommunications technology are currently changing at a rapid pace. SANParks is currently in the process of determining which sorts of communications are most appropriate within a National Park. The Private Party acknowledges, therefore, that SANParks' determination as to what is acceptable may change over time, and that it will be expected to comply at all times with SANParks' OMP and recommended "best practices."

## **50.6 Bulk Infrastructure**

### **50.6.1 Electricity**

Provision of electricity from the national grid is already in place for most of the facilities proposed for outsourcing, except picnic sites. Some Private Parties may wish to utilise alternative energy sources, including solar power or generators. If new solar panels are installed, their visual impacts must be considered, along with the disposal of batteries and their by-products. Generators are permitted, although potential environmental impacts (noise, potential contamination from oil and fuel spills) must be considered in the OMP and EMP and, if approved, effective mitigation measures implemented to address these impacts.

## **50.6.2 Water**

50.6.2.1 Water is a scarce resource in South Africa, and the facilities' size in respect to available water resources must be considered, particularly if the Bidder intends to expand the facility significantly. Given constraints on water supplies in many National Parks, SANParks encourages systems that enable reuse of treated water. The water allocation and requirements should also be determined by the OMP and subjected to subsequent audits.

50.6.2.2 Under the provisions of the National Water Act,<sup>2</sup> South African law requires that a permit be obtained from the Department of Water Affairs and Forestry (DWAF) for use of water from both surface and underground sources. The DWAF permit requirement applies to existing developments. SANParks will monitor the use of all water. In circumstances where there is insufficient water the Private Party will be required to reduce consumption accordingly.

50.6.2.3 It is important to remember that elephants occur in abundance in several Parks and any underground water pipes must be buried to a minimum depth of 1 meter to ensure that they are not unearthed or otherwise damaged.

## **50.7 Communications Infrastructure**

### **50.7.1 Telephones**

50.7.1.1 The Private Party must arrange for service with the appropriate telephone company.

50.7.1.2 Private Parties may not utilise SANParks' radio networks, other than at picnic sites, where the existing radio network can be used for emergencies.

## **50.8 Waste Management**

### **50.8.1 Liquid Waste**

All kitchen drains must be equipped with fat or grease traps. Fuels, solvents,

---

<sup>2</sup> Government of South Africa, 1998. *National Water Act (No, 36 of 1998)*.

cleansers and other liquids must be stored in areas equipped with secondary containment structures to prevent contamination of soil, groundwater and surface waters due to accidental spills. These must be removed from the facility and disposed of in accordance with all applicable national, local or SANParks' requirements.

### **50.8.2 Solid Wastes**

50.8.2.1 Private Parties must use biodegradable packaging wherever possible and specifically may **not use** plastic shopping bags or polystyrene or aluminium in the operation. Security systems that use plastic wrapping to seal travel bags will not be allowed at the airport. SANParks requires Private Parties to implement a policy of sorting and recycling solid wastes. Wastes that cannot be recycled must be removed from the Protected Area and disposed of appropriately. Burning or incinerating in the Protected Area by the Private Party is prohibited. New landfills are not permitted. Biodegradable wastes must be disposed of in incinerators or in approved waste site outside the Protected Area. SANParks will process Private Parties' biodegradable wastes in its incinerators, where these are available and providing the units have sufficient capacity. SANParks will charge the Private Party a fee for disposal services, on a cost recovery basis. The Private Party will be required to transport wastes to these units in a responsible manner.

50.8.2.2 Solid wastes may need to be stored before being processed or removed from the Skukuza Airport. All such storage facilities must be secured from wildlife and constructed to ensure that pollution does not occur.

50.8.2.3 Solid waste management during both the Construction and Operational Phases must be included as items in the EMP and OMP.

### **50.8.3 Noxious Fumes**

The Private Party must ensure that the level of smoke and noxious or other fumes emanating from the Skukuza Airport are acceptable in the context of a Protected Area and the OMP.

## **50.9 Fire Management**

50.9.1 Fire management is an important concern in all Protected Areas and is a major policy

and operational issue in the Kruger National Park. The Private Party must familiarise itself with the relevant fire policies and procedures relevant to the Skukuza Airport.

50.9.2 The Private Party must subject the existing designs plus any proposed modifications to a 'fire safety audit' carried out by a qualified fire safety expert. Recommendations made in the audit report must be incorporated into the EMP and OMP.

50.9.3 The operator undertakes to avail the airport's fire fighting equipment to SANParks for use in other duties not specific to the airport, i.e. extinguishing of veld fires at a reasonable pre-determined per kilometre rate. A separate agreement with SANParks will be drafted in this regard.

## 50.10 **Staff Issues**

### 50.10.1 **Construction Workers**

SANParks will make arrangements for gate access to the Skukuza Airport for all permanent and casual workers involved with any construction to the Skukuza Airport on the same basis as for SANParks' contractors, if applicable. The total number of people to be employed on site during construction must be provided to SANParks. The Private Party must abide by all of the recommendations presented in the construction phase EMP. The Private Party must maintain close communication and co-ordination with Protected Area staff throughout the construction phase.

### 50.10.2 **Staff Accommodation**

50.10.2.1 The Private Party must accommodate as many staff as practical off-site, out of the Camp, as doing so commonly reduces environmental and social impacts. However, seeing that this is not always possible, SANParks has identified and allocated a number of units in the Skukuza Staff Village to the Operator on a rental basis (refer SCHEDULE 14 – EMPLOYEE HOUSING AND RENTALS to this PPP Agreement). Bidders' Proposals must indicate the number of people to be accommodated on site, including family members.

50.10.2.2 The Private Party may decide to house staff outside the Protected Area, in which case the Private Party should arrange for transport for the staff. Due to the airport operating hours it is very unlikely that the Private Party will require before and after hours gate access. However, should there be

a need for this SANParks will consider this and not withhold permission for this unreasonably.

### **50.10.3 Collection of Natural Resources by Staff**

No natural resources may be collected and used within any Protected Area without written approval from SANParks. Specifically, the collection of firewood for cooking and other uses is not permitted, during either the construction or operational Phase. If firewood is brought in from outside the Protected Area, it must be done in accordance with relevant Protected Area policies. Some Parks may only permit the use of firewood from approved alien vegetation clearing operations. Campfires, gas cookers and outdoor recreation facilities will only be allowed as agreed with SANParks in writing.

### **50.10.4 Staff Health and Safety**

The health and safety of staff and their families must be ensured at all times, including when commuting between accommodation facilities and places of work. The Private Party must implement a staff medical plan that complies with current Legislation. The Private Party must also have an emergency medical evacuation policy that covers both guests and staff in the event of a serious injury or acute medical emergency. Relevant staff must be trained in and be aware of this policy. All buildings, vehicles, machinery and other structures (including their operation) must comply with relevant South African Legislation and SANParks standards. The design, layout and operation of the Skukuza Airport must take cognisance of dangerous animals that occur and roam in the vicinity of the Airport.

## **50.11 Access**

50.11.1 All deliveries and other vehicles entering Parks will have to do so through SANParks designated or otherwise agreed entrance gates and will be subject to the same rules and Regulations applicable to SANParks' personnel. Standard opening and closing times will apply.

50.11.2 The Private Party must ensure that its contractors, suppliers and the like adhere to all the access rules and Regulations applicable to SANParks personnel. Wherever possible the Private Party and anyone claiming title through them must try and reduce the volume of traffic on the roads.

50.11.3 The road deaths of animals inside the Protected Area have shown a dramatic increase over the last few years. Accordingly, should suppliers to the Private Party receive 3 (three) traffic offences within the Protected Area, such suppliers shall be blacklisted and entry to the Protected Area shall be prohibited for a period of 2 (two) years. The Private Party should ensure that their suppliers are aware of travel times and speed limits to avoid them being banned from the Protected Area.

50.12 **Monitoring**

50.12.1 All of the issues discussed and described in this document will require monitoring. SANParks reserves the right to monitor all these issues according to the standards set out in these Specifications, the findings of the EIA (if one is required), and/or in a manner agreed between the parties as the process develops.

50.12.2 The Private Party will be obliged to develop a comprehensive monitoring, auditing and review system and implement the system at the Skukuza Airport at their own cost.

50.13 **Meteorological Equipment**

The Private Party shall not be permitted to interfere with existing weather and/or measuring equipment at formal or informal weather stations.

**51. SCHEDULE 10 – PRIVATE PARTY CONSTITUTIONAL DOCUMENTS**

**52. SCHEDULE 11 – INSURANCE**



53. **SCHEDULE 12 – PERFORMANCE BOND**

**PART A – FORM OF PERFORMANCE BOND**

To be provided to South African National Parks having its principal place of business at [ ](hereinafter called “**SANParks**”)

Whereas:

1. SANParks has awarded a PPP Agreement for the Management and Operation of the Skukuza Airport in the Kruger National Park under a PPP Agreement (hereinafter called the “**PPP Agreement**”) to [ ] (hereinafter called the “**Private Party**”); and
2. The Private Party is obliged by the terms of the PPP Agreement to provide this Bond to the amount of R 150,000-00 (One Hundred and Fifty Thousand Rand) to SANParks to secure the performance of its obligations under the PPP Agreement.

We, the undersigned

\_\_\_\_\_ and \_\_\_\_\_  
(Name) (Name)

acting herein as

\_\_\_\_\_ and \_\_\_\_\_  
(Position) (Position)

of

\_\_\_\_\_ (hereinafter called the “**Bank**”)

being duly authorised to sign and incur obligations in the name of the Bank under and in terms of a Resolution of the Board of Directors of the Bank, a certified copy of which is annexed hereto, hereby irrevocably and unconditionally guarantee and undertake on behalf of the Bank that:

- 1 The Bank shall pay amounts not exceeding R \_\_\_\_\_ (\_\_\_\_\_ Rand) in aggregate (the “**Maximum Amount**”) without delay, on receipt by the Bank of the first written demand of SANParks that the amount is due and payable and without proof of any breach or

other default. The Bank shall pay such amount(s) to **SANParks** upon receipt of a certificate in the form attached signed by an authorised representative of SANParks certifying that SANParks is entitled to draw on this Bond pursuant to the provisions of the PPP Agreement (the “**Certificate**”). SANParks may make partial and/or multiple demands under this Bond provided that the aggregate of amounts paid under this Bond shall not exceed the Maximum Amount.

2 The demand for payment together with this Bond (or a certified copy hereof) and the Certificate shall constitute prima facie proof of the Bank’s indebtedness hereunder for the purposes of any proceedings including but not limited to provisional sentence proceedings instituted against the Bank in any court of law having jurisdiction.

3 Neither the failure of SANParks nor of the Private Party respectively to enforce strict or substantial compliance by the Private Party or any contractor or sub-contractor with their respective obligations nor any act, conduct, or omission by SANParks or Private Party prejudicial to the interests of the Bank including, without limitation, the granting of time or any other indulgence to the Private Party, any contractor or sub-contractor or any other person or by amendment to or variation or waiver of terms of the PPP Agreement, any sub-contract or any ancillary or related document (the “Underlying Documents”) will discharge the Bank from liability under this Bond. For the avoidance of doubt, the Bank’s liability under this Bond will not be discharged notwithstanding the winding up, dissolution or judicial management of the Private Party, any contractor or sub-contractor or any other Person and the Bond shall be honoured regardless of the invalidity, illegality or unenforceability of the Underlying Documents.

4 This Bond shall:

4.1 remain in full force and effect from the date hereof, and shall expire on the earlier of:

4.1.1 the issuance of a replacement Bond in accordance with the terms of the PPP Agreement;

4.1.2 90 (ninety) Business Days after the expiry or earlier termination of the PPP Agreement; or

4.1.3 the date when the Bank has paid to SANParks an amount which is equal to (or amounts which in aggregate total) the Maximum Amount;

4.2 exist independently of the PPP Agreement or any amendment, variation or novation thereof;

- 4.3 not be ceded, assigned or otherwise transferred by SANParks, or otherwise dealt with in any manner whatsoever (save for the purposes and in the manner referred to above) which has or may have the effect of transferring or encumbering or alienating SANParks' rights hereunder;
- 4.4 be returned to the Bank on its expiry, cancellation, withdrawal or this Bond being fully drawn; and
- 4.5 be governed by the laws of the Republic of South Africa.
- 5 The Bank shall deposit any payment made under this Bond into an account designated by SANParks.
- 6 The Bank shall make any payment demanded under this Bond free, clear of and without any deduction, withholding, counterclaim or set-off of any kind. If the Bank is required by law to make payments subject to the deduction or withholding of tax, it will make such further payments as are necessary to ensure that the amounts paid to SANParks equal the amounts that would have been paid to SANParks had no such deduction or withholding been made or been required to be made.
- 7 The obligations of the Bank under this Bond shall not in any way be affected by the invalidity, illegality or unenforceability for any reason of the obligations of the Private Party.
- 8 The Bank shall have no right of recourse or claim of whatever nature against SANParks arising out of its obligation to pay or arising out of actual payment under this Bond to SANParks.
- 9 Addresses and Notices:
- 9.1 The parties hereto choose *domicilium citandi et executandi* for all purposes of and in connection with this PPP Agreement as follows:
- SANParks:  
\_\_\_\_\_  
Telefax: \_\_\_\_\_
- The Bank: \_\_\_\_\_  
Telefax: \_\_\_\_\_
- 9.2 Any party hereto shall be entitled to change its *domicilium* from time to time, provided that any new *domicilium* selected by it shall be a physical address in the Republic of South Africa, and any such change shall only be effective upon receipt of notice in writing by the other party of such change.

- 9.3 All notices, demands, communications or payments intended for any party shall be made or given at such party's *domicilium* for the time being.
- 9.4 Any notice required or permitted to be given under this Bond shall be valid and effective only if in writing.
- 9.5 A notice sent by one party to another party shall be deemed to be received
- 9.5.1 on the same day, if delivered by hand;
- 9.5.2 on the same day of transmission, if sent by telefax with a receipt confirming completion of transmission.
- 9.6 Notwithstanding anything to the contrary herein contained a written notice or communication actually received by a party shall be an adequate written notice or communication to it notwithstanding that it was not sent to or delivered at its chosen *domicilium citandi et executandi*.

SIGNED ON \_\_\_\_\_ 2008

AT \_\_\_\_\_ (Place)

SIGNATURE \_\_\_\_\_ SIGNATURE \_\_\_\_\_

[NAME] [NAME]

[TITLE] [TITLE]

WITNESS 1 \_\_\_\_\_ WITNESS 2 \_\_\_\_\_

**PART B: FORM OF CERTIFICATE**

To: [Name and address of Bank]

Attention:

From: South African National Parks

Address:

Dated:

Dear Sirs

**Performance Bond Dated [insert date] (the "Bond")**

We refer to the above Bond issued by you. Terms defined in the Bond shall have the same meaning when used in this Certificate.

SANParks is entitled to call on this Bond under the PPP Agreement and we demand payment of the sum of R[ ] under the Bond. Payment is to be made in accordance with the provisions of the Bond.

Payment must be made without delay to [**SANParks** bank account details].

Yours faithfully,

.....

for and on behalf of

South African National Parks

## 54. SCHEDULE 13 – CAPITAL EXPENDITURE PLAN

### 54.1 Introduction

54.1.1 The Private Party shall be obliged to comply with and adhere to the Capital Expenditure Plan as proposed with the Private Party's Bid Submission attached hereto.

54.1.2 Failure by the Private Party to comply with the provisions of this SCHEDULE 13 – CAPITAL EXPENDITURE PLAN to the PPP Agreement and the Private Party Default is not remedied before the expiry of the period referred to in the notice by the Institution; the Institution may terminate this PPP Agreement with immediate effect by written notice to the Private Party.

### 54.2 Details on Capital Expenditure

54.2.1 Total amount to be spent:

54.2.2 Breakdown of capital expenditure:

54.2.2.1 Expenditure on Skukuza Airport Buildings: <Rx> by <date> for <details>

54.2.2.2 Expenditure on assets:

54.2.2.2.1 Fire fighting Equipment: <Rx> by <date> for <details>

54.2.2.2.2 Other equipment: <Rx> by <date> for <details>

54.2.2.3 Maintenance to Airport: <Rx> by <date> for <details>

**55. SCHEDULE 14 – EMPLOYEE HOUSING AND RENTALS**

| Camp    | Location                  | House / Unit Number | Occupant  | Size           | Tariff Calc |
|---------|---------------------------|---------------------|---|----------------|-------------|
| Skukuza | Rest Camp & Staff Village | 228                 | Airports Manager                                    | 4 bedroom      | R 3455      |
| Skukuza | Rest Camp & Staff Village | 78                  | Admin Manager                                       | 3 bedroom      | R 3160      |
| Skukuza | Parkhome                  |                     | Airline Supervisor                                  | 2 bedroom unit | R 1780      |
| Skukuza | Parkhome                  |                     | Airline Supervisor                                  | 2 bedroom unit | R 1780      |
| Skukuza | Parkhome                  |                     | Check-in staff, baggage handlers and cleaning staff | 2 bedroom unit | R 1780      |
| Skukuza | Parkhome                  |                     | Check-in staff, baggage handlers and cleaning staff | 2 bedroom unit | R 1780      |
| Skukuza | Living Quarters           |                     | Check-in staff, baggage handlers and cleaning staff | Single         | R 190       |
| Skukuza | Living Quarters           |                     | Check-in staff, baggage handlers and cleaning staff | Single         | R 190       |
| Skukuza | Living Quarters           |                     | Check-in staff, baggage handlers and cleaning staff | Single         | R 190       |
| Skukuza | Living Quarters           |                     | Check-in staff, baggage handlers and cleaning staff | Single         | R 190       |
| Skukuza | Living Quarters           |                     | Check-in staff, baggage handlers and cleaning staff | Single         | R 190       |

**56. SCHEDULE 15 – PRIVATE PARTY LOAN AGREEMENTS**



**57. SCHEDULE 16 - TRIBAL AUTHORITIES NEIGHBOURING THE KNP**

The Tribal Authorities listed below are defined as any village which falls within the 20 km radius within the western border of KNP.

**57.1 Ntirhiswano Forum Tribal Authorities**

57.1.1 Hoxane

57.1.2 Jongilanga

57.1.3 Contact person: Ellem Mkhonto 082 407 4788

**57.2 Lubambiswano Forum Tribal Authorities**

57.2.1 Msongwaba

57.2.2 Mdluli

57.2.3 Lumshiyo

57.2.4 Mpakeni

57.2.5 Gutshwa

57.2.6 Mbuyane

57.2.7 Masoyi

57.2.8 Nkambeni

57.2.9 Contact person: E. Mthombothi 082 328 1754

**57.3 Mahlamba Ndlopfu Forum Tribal Authorities**

57.3.1 Mnisi

57.3.2 Amashangana

57.3.3 Contact person: Jimmy Mgiba 083 6699 540

**57.4 Nkomazi – Sukumani Forum Tribal Authorities**

57.4.1 Siboshwa

57.4.2 Lugendlane

57.4.3 Hoyi

57.4.4 Mhlamba

57.4.5 Mlambo

57.4.6 Mawewe

57.4.7 Shongwe

57.4.8 Contact person: Maseko M.A 082 5825 721

**57.5 Hlanganani Forum Tribal Authorities**

57.5.1 Mhinga

57.5.2 Mtititi

57.5.3 Makukule

57.5.4 Madonsi

57.5.5 Magona

57.5.6 Xiviti

57.5.7 Contact person: F.S. Mhinga 072 287 6845

**57.6 Makuya Forum Tribal Authorities**

57.6.1 Makuya

57.6.2 Mutale

57.6.3 Lambani

57.6.4 Mushiri

57.6.5 Vhurivhuri

57.6.6 Contact person: L.T. Ramagona 072 768 6231

**57.7 Phalaborwa Forum Tribal Authorities**

57.7.1 Makhushane

57.7.2 Maseke

57.7.3 Ba- Shaiditlou

57.7.4 Majeje

57.7.5 Selwane

57.7.6 Mthimkhulu

57.7.7 Makhuva

57.7.8 Sawulana

57.7.9 Contact person: Godfrey Lesufi 082 711 4311

58. SCHEDULE 17 – FLIGHT PATHS

Final Flight Path to be confirmed

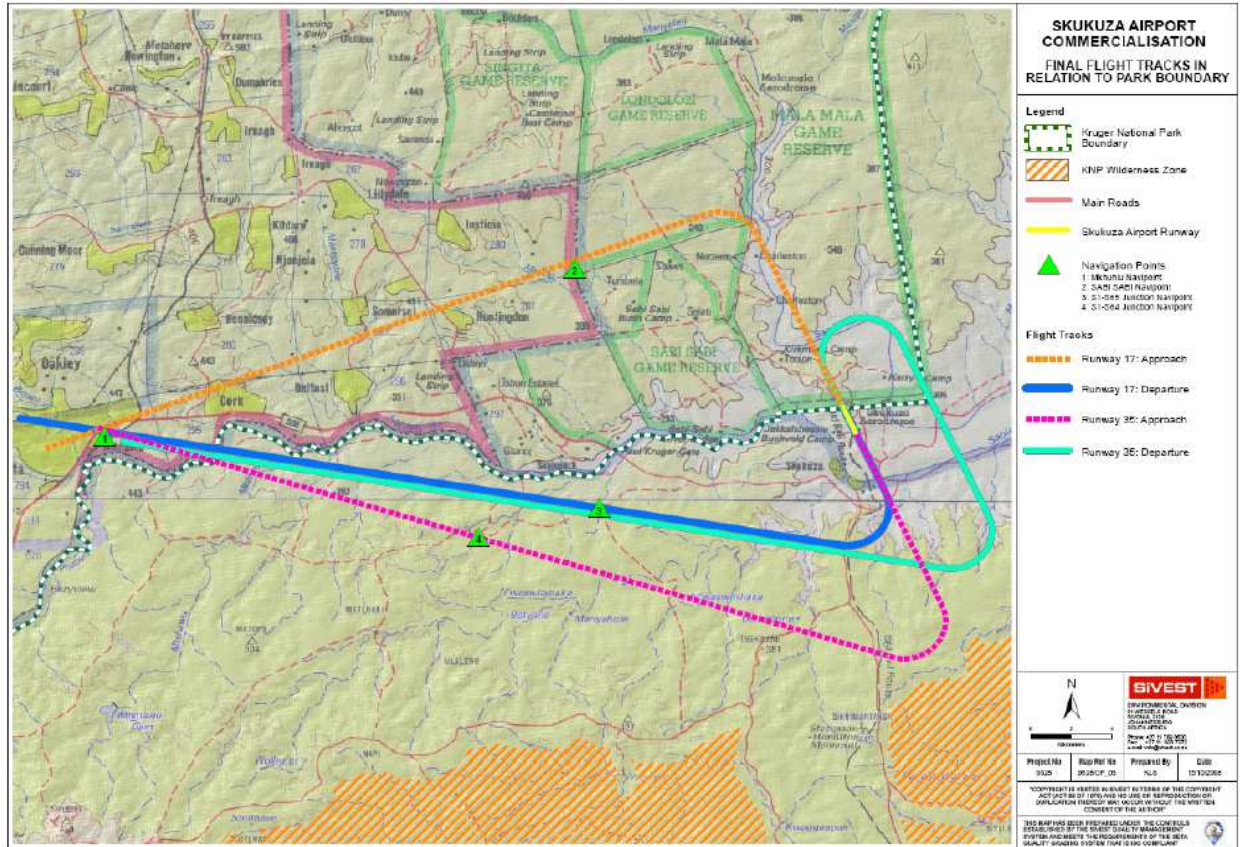

**59. SCHEDULE 18 – PCN CALCULATION REPORT**

**60. SCHEDULE 19 – DRAFT EMP AND SPECIALIST STUDY FOR THE  
COMMERCIALISATION OF THE SKUKUZA AIRPORT (SIVEST)**